

# CONSOLIDATED VERSION



---

**Household and similar electrical appliances – Safety –  
Part 2-103: Particular requirements for drives for gates, doors and windows**





## **THIS PUBLICATION IS COPYRIGHT PROTECTED**

**Copyright © 2017 IEC, Geneva, Switzerland**

All rights reserved. Unless otherwise specified, no part of this publication may be reproduced or utilized in any form or by any means, electronic or mechanical, including photocopying and microfilm, without permission in writing from either IEC or IEC's member National Committee in the country of the requester. If you have any questions about IEC copyright or have an enquiry about obtaining additional rights to this publication, please contact the address below or your local IEC member National Committee for further information.

IEC Central Office  
3, rue de Varembe  
CH-1211 Geneva 20  
Switzerland

Tel.: +41 22 919 02 11  
Fax: +41 22 919 03 00  
[info@iec.ch](mailto:info@iec.ch)  
[www.iec.ch](http://www.iec.ch)

### **About the IEC**

The International Electrotechnical Commission (IEC) is the leading global organization that prepares and publishes International Standards for all electrical, electronic and related technologies.

### **About IEC publications**

The technical content of IEC publications is kept under constant review by the IEC. Please make sure that you have the latest edition, a corrigenda or an amendment might have been published.

#### **IEC Catalogue - [webstore.iec.ch/catalogue](http://webstore.iec.ch/catalogue)**

The stand-alone application for consulting the entire bibliographical information on IEC International Standards, Technical Specifications, Technical Reports and other documents. Available for PC, Mac OS, Android Tablets and iPad.

#### **IEC publications search - [www.iec.ch/searchpub](http://www.iec.ch/searchpub)**

The advanced search enables to find IEC publications by a variety of criteria (reference number, text, technical committee,...). It also gives information on projects, replaced and withdrawn publications.

#### **IEC Just Published - [webstore.iec.ch/justpublished](http://webstore.iec.ch/justpublished)**

Stay up to date on all new IEC publications. Just Published details all new publications released. Available online and also once a month by email.

#### **Electropedia - [www.electropedia.org](http://www.electropedia.org)**

The world's leading online dictionary of electronic and electrical terms containing 20 000 terms and definitions in English and French, with equivalent terms in 16 additional languages. Also known as the International Electrotechnical Vocabulary (IEV) online.

#### **IEC Glossary - [std.iec.ch/glossary](http://std.iec.ch/glossary)**

65 000 electrotechnical terminology entries in English and French extracted from the Terms and Definitions clause of IEC publications issued since 2002. Some entries have been collected from earlier publications of IEC TC 37, 77, 86 and CISPR.

#### **IEC Customer Service Centre - [webstore.iec.ch/csc](http://webstore.iec.ch/csc)**

If you wish to give us your feedback on this publication or need further assistance, please contact the Customer Service Centre: [csc@iec.ch](mailto:csc@iec.ch).



IEC 60335-2-103

Edition 3.1 2017-10

# CONSOLIDATED VERSION



---

**Household and similar electrical appliances – Safety –  
Part 2-103: Particular requirements for drives for gates, doors and windows**

INTERNATIONAL  
ELECTROTECHNICAL  
COMMISSION

---

ICS 13.120; 91.060.50

ISBN 978-2-8322-4963-5

**Warning! Make sure that you obtained this publication from an authorized distributor.**



## REDLINE VERSION



---

**Household and similar electrical appliances – Safety –  
Part 2-103: Particular requirements for drives for gates, doors and windows**



## CONTENTS

FOREWORD.....	5
INTRODUCTION.....	8
1 Scope.....	9
2 Normative references .....	10
3 Terms and definitions .....	10
4 General requirement.....	11
5 General conditions for the tests .....	11
6 Classification.....	12
7 Marking and instructions.....	12
8 Protection against access to live parts.....	14
9 Starting of motor-operated appliances .....	15
10 Power input and current.....	15
11 Heating.....	15
12 Void.....	15
13 Leakage current and electric strength at operating temperature.....	15
14 Transient overvoltages .....	16
15 Moisture resistance .....	16
16 Leakage current and electric strength.....	16
17 Overload protection of transformers and associated circuits .....	16
18 Endurance.....	16
19 Abnormal operation .....	16
20 Stability and mechanical hazards.....	17
21 Mechanical strength .....	17
22 Construction .....	17
23 Internal wiring.....	18
24 Components .....	18
25 Supply connection and external flexible cords .....	18
26 Terminals for external conductors.....	19
27 Provision for earthing .....	19
28 Screws and connections.....	19
29 Clearances, creepage distances and solid insulation .....	19
30 Resistance to heat and fire.....	19
31 Resistance to rusting.....	20
32 Radiation, toxicity and similar hazards.....	20
Annexes .....	23
Annex R (normative) Software evaluation .....	24
Annex AA (normative) Drives for powered pedestrian doors used in emergency routes and emergency exits.....	25
Annex DD (normative) Drives for horizontally and vertically moving doors and gates .....	38
Annex EE (normative) Measuring point for protective devices of horizontally moving pedestrian doors.....	45
Annex BB (normative) Drives for windows.....	27

Annex CC (normative) Drives for pedestrian doors.....	33
Annex FF (normative) Reference bodies .....	54
Annex GG (normative) Test method of entrapment protection system of drives for revolving doors .....	56
GG.1 Main closing edge/opposing closing edge – no contact protection .....	56
GG.2 Main closing edge/opposing closing edge – contact protection.....	56
GG.3 Secondary closing edge/floor .....	56
GG.4 Main closing edge/inside wall.....	56
Annex HH (normative) Limitation of impact forces of pedestrian doors .....	57
HH.1 Permissible dynamic forces.....	57
HH.2 Permissible static forces .....	58
HH.3 Impact force measuring equipment .....	58
HH.4 Field impact force measuring equipment .....	59
Annex II (normative) Measuring points for limitation of impact forces of pedestrian doors .....	60
Annex JJ (normative) Low energy movement of pedestrian doors .....	63
JJ.1 Low energy movement .....	63
JJ.1.1 General .....	63
JJ.1.2 Additional requirements for low-energy movement of hinged and swing doorsets .....	63
Annex KK (normative) Speed setting for low energy movement of pedestrian doors.....	64
KK.1 Speed settings for low energy power operated swing doorsets.....	64
KK.2 Speed settings for low energy sliding doorsets.....	64
Annex LL (normative) Safeguarding of swing pedestrian doors .....	66
Bibliography.....	68
Figure 101 – Examples of driven parts .....	21
Figure 102 – Inactive floor areas of pressure-sensitive pads .....	22
Figure CC.1 – Safety distances for opening movement of swing door .....	37
Figure EE.1 – Single-leaf sliding doorset .....	45
Figure EE.2 – Double-leaf sliding doorset .....	45
Figure EE.3 – Single-leaf swing doorset.....	46
Figure EE.4 – Double-leaf swing doorset .....	46
Figure EE.5 – Folding doorset.....	47
Figure EE.6 – Revolving doorset, two leaves .....	49
Figure EE.7 – Revolving doorset, three leaves.....	51
Figure EE.8 – Revolving doorset, four leaves.....	53
Figure FF.1 – Reference bodies.....	55
Figure HH.1 – Force versus time.....	58
Figure II.1 – Single-leaf sliding doorset .....	60
Figure II.2 – Double-leaf sliding doorset.....	60
Figure II.3 – Folding doorset .....	61
Figure II.4 – Revolving doorset, 2-leaf .....	61
Figure II.5 – Revolving doorset, 3-leaf .....	62
Figure II.6 – Revolving doorset, 4-leaf .....	62
Figure LL.1 – Areas of the door sweep.....	66

Table HH.1 – Permissible dynamic forces .....	57
Table KK.1 – Speed settings.....	64
Table KK.2 – Minimum travelling time per doorset leaf vs. mass of door leaf .....	65
Table LL.1 – Minimum width of door leaf to be protected vs. radius of doorset and doorset travelling time.....	67

INTERNATIONAL ELECTROTECHNICAL COMMISSION

**HOUSEHOLD AND SIMILAR ELECTRICAL APPLIANCES –  
SAFETY –**

**Part 2-103: Particular requirements for drives  
for gates, doors and windows**

FOREWORD

- 1) The International Electrotechnical Commission (IEC) is a worldwide organization for standardization comprising all national electrotechnical committees (IEC National Committees). The object of IEC is to promote international co-operation on all questions concerning standardization in the electrical and electronic fields. To this end and in addition to other activities, IEC publishes International Standards, Technical Specifications, Technical Reports, Publicly Available Specifications (PAS) and Guides (hereafter referred to as "IEC Publication(s)"). Their preparation is entrusted to technical committees; any IEC National Committee interested in the subject dealt with may participate in this preparatory work. International, governmental and non-governmental organizations liaising with the IEC also participate in this preparation. IEC collaborates closely with the International Organization for Standardization (ISO) in accordance with conditions determined by agreement between the two organizations.
- 2) The formal decisions or agreements of IEC on technical matters express, as nearly as possible, an international consensus of opinion on the relevant subjects since each technical committee has representation from all interested IEC National Committees.
- 3) IEC Publications have the form of recommendations for international use and are accepted by IEC National Committees in that sense. While all reasonable efforts are made to ensure that the technical content of IEC Publications is accurate, IEC cannot be held responsible for the way in which they are used or for any misinterpretation by any end user.
- 4) In order to promote international uniformity, IEC National Committees undertake to apply IEC Publications transparently to the maximum extent possible in their national and regional publications. Any divergence between any IEC Publication and the corresponding national or regional publication shall be clearly indicated in the latter.
- 5) IEC itself does not provide any attestation of conformity. Independent certification bodies provide conformity assessment services and, in some areas, access to IEC marks of conformity. IEC is not responsible for any services carried out by independent certification bodies.
- 6) All users should ensure that they have the latest edition of this publication.
- 7) No liability shall attach to IEC or its directors, employees, servants or agents including individual experts and members of its technical committees and IEC National Committees for any personal injury, property damage or other damage of any nature whatsoever, whether direct or indirect, or for costs (including legal fees) and expenses arising out of the publication, use of, or reliance upon, this IEC Publication or any other IEC Publications.
- 8) Attention is drawn to the Normative references cited in this publication. Use of the referenced publications is indispensable for the correct application of this publication.
- 9) Attention is drawn to the possibility that some of the elements of this IEC Publication may be the subject of patent rights. IEC shall not be held responsible for identifying any or all such patent rights.

**DISCLAIMER**

**This Consolidated version is not an official IEC Standard and has been prepared for user convenience. Only the current versions of the standard and its amendment(s) are to be considered the official documents.**

**This Consolidated version of IEC 60335-2-103 bears the edition number 3.1. It consists of the third edition (2015-04) [documents 61/4877A/FDIS and 61/4913/RVD] and its amendment 1 (2017-10) [documents 61/5296/CDV and 61/5382A/RVC]. The technical content is identical to the base edition and its amendment.**

**In this Redline version, a vertical line in the margin shows where the technical content is modified by amendment 1. Additions are in green text, deletions are in strikethrough red text. A separate Final version with all changes accepted is available in this publication.**

This part of International Standard IEC 60335 has been prepared by IEC technical committee 61: Safety of household and similar electrical appliances.

This third edition constitutes a technical revision.

The principal changes in this edition as compared with the second edition of IEC 60335-2-103 are as follows (minor changes are not listed):

- modification of requirements in Clause 20 by introduction of new annexes.

This publication has been drafted in accordance with the ISO/IEC Directives, Part 2.

This part 2 is to be used in conjunction with the latest edition of IEC 60335-1 and its amendments. It was established on the basis of the fifth edition (2010) of that standard.

NOTE 1 When “Part 1” is mentioned in this standard, it refers to IEC 60335-1.

This part 2 supplements or modifies the corresponding clauses in IEC 60335-1, so as to convert that publication into the IEC standard: Safety requirements for electric drives for gates, doors and windows.

When a particular subclause of Part 1 is not mentioned in this part 2, that subclause applies as far as is reasonable. When this standard states “addition”, “modification” or “replacement”, the relevant text in Part 1 is to be adapted accordingly.

NOTE 2 The following numbering system is used:

- subclauses, tables and figures that are numbered starting from 101 are additional to those in Part 1;
- unless notes are in a new subclause or involve notes in Part 1, they are numbered starting from 101, including those in a replaced clause or subclause;
- additional annexes are lettered AA, BB, etc.

NOTE 3 The following print types are used:

- requirements: in roman type;
- *test specifications: in italic type;*
- notes: in small roman type.

Words in **bold** in the text are defined in Clause 3. When a definition concerns an adjective, the adjective and the associated noun are also in bold.

A list of all parts of the IEC 60335 series, under the general title: *Household and similar electrical appliances – Safety*, can be found on the IEC website.

The committee has decided that the contents of the base publication and its amendment will remain unchanged until the stability date indicated on the IEC web site under "<http://webstore.iec.ch>" in the data related to the specific publication. At this date, the publication will be

- reconfirmed,
- withdrawn,
- replaced by a revised edition, or
- amended.

NOTE 4 The attention of National Committees is drawn to the fact that equipment manufacturers and testing organizations may need a transitional period following publication of a new, amended or revised IEC publication in which to make products in accordance with the new requirements and to equip themselves for conducting new or revised tests.

It is the recommendation of the committee that the content of this publication be adopted for implementation nationally not earlier than 12 months or later than 36 months from the date of publication.

The following differences exist in the countries indicated below.

- 6.1: Class 0 and class 01 are allowed for **drives** for indoor use having a rated voltage up to 150 V (Japan).

**IMPORTANT – The 'colour inside' logo on the cover page of this publication indicates that it contains colours which are considered to be useful for the correct understanding of its contents. Users should therefore print this document using a colour printer.**

## INTRODUCTION

It has been assumed in the drafting of this International Standard that the execution of its provisions is entrusted to appropriately qualified and experienced persons.

This standard recognizes the internationally accepted level of protection against hazards such as electrical, mechanical, thermal, fire and radiation of appliances when operated as in normal use taking into account the manufacturer's instructions. It also covers abnormal situations that can be expected in practice and takes into account the way in which electromagnetic phenomena can affect the safe operation of appliances.

This standard takes into account the requirements of IEC 60364 as far as possible so that there is compatibility with the wiring rules when the appliance is connected to the supply mains. However, national wiring rules may differ.

If an appliance within the scope of this standard also incorporates functions that are covered by another part 2 of IEC 60335, the relevant part 2 is applied to each function separately, as far as is reasonable. If applicable, the influence of one function on the other is taken into account.

When a part 2 standard does not include additional requirements to cover hazards dealt with in Part 1, Part 1 applies.

NOTE 1 This means that the technical committees responsible for the part 2 standards have determined that it is not necessary to specify particular requirements for the appliance in question over and above the general requirements.

This standard is a product family standard dealing with the safety of appliances and takes precedence over horizontal and generic standards covering the same subject.

NOTE 2 Horizontal and generic standards covering a hazard are not applicable since they have been taken into consideration when developing the general and particular requirements for the IEC 60335 series of standards. For example, in the case of temperature requirements for surfaces on many appliances, generic standards, such as ISO 13732-1 for hot surfaces, are not applicable in addition to Part 1 or part 2 standards.

An appliance that complies with the text of this standard will not necessarily be considered to comply with the safety principles of the standard if, when examined and tested, it is found to have other features that impair the level of safety covered by these requirements.

An appliance employing materials or having forms of construction differing from those detailed in the requirements of this standard may be examined and tested according to the intent of the requirements and, if found to be substantially equivalent, may be considered to comply with the standard.

## HOUSEHOLD AND SIMILAR ELECTRICAL APPLIANCES – SAFETY –

### Part 2-103: Particular requirements for drives for gates, doors and windows

#### 1 Scope

This clause of Part 1 is replaced by the following.

This International Standard deals with the safety of electric **drives** for horizontally and vertically moving gates, doors, garage doors and **windows** for household and similar purposes, their **rated voltage** being not more than 250 V for single-phase **drives** and ~~480~~ 600 V for other **drives**. It also covers the hazards associated with the movement of the **driven part**.

Battery-operated drives and other d.c. supplied **drives** are within the scope of this standard. Dual supply **drives**, either mains-supplied or battery-operated, are regarded as battery-operated **drives** when operated in the battery mode.

**Drives** not intended for normal household use but which nevertheless may be a source of danger to the public, such as **drives** intended to be used by laymen in shops, offices, hotels, restaurants, hospitals, in industry and on farms, are within the scope of this standard.

Requirements for **drives** for doors that may be used in emergency routes and exits are given in Annex AA.

NOTE 101 Examples of **drives** within the scope of this standard are **drives** for

- folding doors;
- revolving doors;
- rolling doors;
- roof **windows**;
- sectional overhead doors;
- swinging and sliding gates or doors.

Examples are shown in Figure 101.

NOTE 102 **Drives** may be supplied with a **driven part**.

As far as is practicable, this standard deals with the common hazards presented by **drives** that are encountered by all persons in and around the home. However, in general, it does not take into account

- persons (including children) whose
  - physical, sensory or mental capabilities; or
  - lack of experience and knowledgeprevents them from using the **drive** safely without supervision or instruction;
- children playing with the **drive**.

NOTE 103 Attention is drawn to the fact that in many countries additional requirements are specified by the national authorities responsible for the protection of labour and similar authorities.

NOTE 104 This standard does not apply to **drives**

- for vertically moving garage doors for residential use (60335-2-95);

- for shutters covering doors and **windows** (including locations where the door is set back from the shutter), awnings, blinds and similar equipment (60335-2-97);
- intended exclusively to be used by trained persons in commercial and industrial premises;
- for specific purposes, such as fire doors;
- for natural smoke exhaust ventilators not used as **windows** (ISO 21927-2);
- intended to be used in locations where special conditions prevail, such as the presence of a corrosive or explosive atmosphere (dust, vapour or gas).

NOTE 105 This standard does not apply to movement of a pedestrian door where such movement is based solely on stored energy.

## 2 Normative references

This clause of Part 1 is applicable except as follows.

*Addition:*

IEC 60068-2-52, *Environmental testing – Part 2: Tests – Test Kb: Salt mist, cyclic (sodium, chloride solution)*

IEC 60825-1:2014, *Safety of laser products – Part 1: Equipment classification and requirements*

IEC 61496-3:2008, *Safety of machinery – Electro-sensitive protective equipment – Part 3: Particular requirements for Active Opto-electronic Protective Devices responsive to Diffuse Reflection (AOPDDR)*

## 3 Terms and definitions

This clause of Part 1 is applicable except as follows.

### 3.1.9 Replacement:

#### **normal operation**

operation of the **drive** under the following conditions

**Drives** supplied without a **driven part** are operated with their **rated load**.

**Drives** supplied with a **driven part** are operated with the **driven part** installed in accordance with the instructions.

### 3.101

#### **drive**

motor and other components that control the movement of the **driven part**

Note 1 to entry: Examples of components are gears, controls, brakes, components for power transmission from the **drive** to the **driven part** and **entrapment protection systems**.

### 3.102

#### **driven part**

part of a gate, door, garage door or **window** that is intended to be moved by the **drive**

### 3.103

#### **window**

part in a building that opens and closes in order to regulate the air and light and that is not intended for passage

**3.104**

**rated load**

force or torque assigned to the **drive** by the manufacturer

**3.105**

**rated operating time**

duration of continuous operation assigned to the **drive** by the manufacturer

Note 1 to entry: During continuous operation, the **drive** may reverse its direction.

**3.106**

**rated number of operating cycles**

number of uninterrupted **cycles** assigned to the **drive** by the manufacturer

**3.107**

**cycle**

complete opening and closing movement of the **driven part**

Note 1 to entry: For revolving doors a **cycle** means the necessary rotation to allow a person to pass through it.

**3.108**

**entrapment protection system**

part of the **drive** that protects against crushing

Note 1 to entry: An **entrapment protection system** may consist of one or more devices, such as pressure sensitive edges, passive infrared and active light sensing devices, **biased-off switches** or motor current monitoring devices.

Note 2 to entry: An **entrapment protection system** may be incorporated in the motor assembly or installed separately.

**3.109**

**biased-off switch**

hold to run device that initiates and maintains the **drive** movement only as long as the manual control is actuated

**3.110**

**automatic drive**

**drive** that operates the **driven part** in at least one direction without intentional activation by the user

**3.111**

**horizontally moving pedestrian door**

swinging, sliding or rotating door designed for pedestrian use

**3.112**

**reversible drive**

**drive** that can be manually operated with or without power in both directions by manual action on the **driven part**

## **4 General requirement**

This clause of Part 1 is applicable.

## **5 General conditions for the tests**

This clause of Part 1 is applicable except as follows.

### **5.2 Addition:**

When a test has to be carried out with a **driven part**, the **driven part** specified for installation with the **drive** that gives the most unfavourable conditions for the test is used. The **drive** is adjusted in accordance with the instructions.

The **driven part** may be simulated by an artificial load.

#### 5.5 Addition:

A wicket door is kept in the fully closed position if it travels together with the door during the tests or in the fully open position or completely removed position if it does not travel with the door during the tests.

#### 5.7 Addition:

If the **drive** is marked with an ambient temperature beyond the range of +5 °C to +40 °C, the tests of Clauses 11, 13, BB.20.101, BB.20.105, BB.20.106, BB.20.107, BB.20.109, CC.20.103, CC.20.104, CC.20.105, CC.20.106, DD.20.105, DD.20.106, DD.20.107, DD.20.108, and 21 are carried out at the most unfavourable marked temperature.

**5.101 Drives** shall be tested for compliance with this standard for any of the following modes of operation as intended by the manufacturer:

- automatic operation (operation in at least one direction without intentional activation by the user);
- impulse activation (operation in either direction with an intentional activation by the user);
- biased-off (hold to run) operation.

Whenever required by the instructions, components shall be added or changed to perform the tests.

## 6 Classification

This clause of Part 1 is applicable except as follows.

### 6.1 Modification:

**Drives** shall be **class I**, **class II** or **class III**.

### 6.2 Addition:

**Drives**, or parts of **drives**, that are intended for exposure to outdoor conditions shall be at least IPX4.

## 7 Marking and instructions

This clause of Part 1 is applicable except as follows.

### 7.1 Addition:

**Drives** shall be marked with their ambient temperature range.

**Drives** supplied without a **driven part** shall be marked with

- the **rated load**, in newtons (N) or in newton-metres (Nm);

- the **rated operating time**, in minutes, unless the **drive** is intended for continuous operation.

**Drives** supplied with a **driven part** shall be marked with the **rated number of operating cycles** or the **cycles** per hour, unless the **drive** is intended for continuous operation.

**7.6 Addition:**



[symbol ISO 7000-0533 (2004-01)]

upper limit of temperature



[symbol ISO 7000-0534 (2004-01)]

lower limit of temperature

**7.12 Addition:**

The instructions shall state the substance of the following:

**WARNING:** Important safety instructions. It is important for the safety of persons to follow these instructions. Save these instructions.

The instructions shall include the substance of the following:

- do not allow children to play with fixed controls. Keep remote controls away from children;
- explanation of mode indicators;
- details on how to use any manual release, or **reversible drive** used as a manual release, and if applicable, state that activation of the manual release may cause uncontrolled movement of the driven part due to mechanical failures or an out-of-balance condition;
- when operating a biased-off switch, make sure that other persons are kept away;
- when closing a window that has been opened by a smoke control system, make sure that other persons are kept away;
- details on how to re-adjust controls, if applicable;
- frequently examine the installation for imbalance where applicable and signs of wear or damage to cables, springs and mounting. Do not use if repair or adjustment is necessary;
- disconnect the supply(s) when cleaning or other maintenance is being carried out.

**7.12.1 Addition:**

The installation instructions shall state the substance of the following:

**WARNING:** Important safety instructions. Follow all instructions since incorrect installation can lead to severe injury.

The installation instructions shall specify the type, size and mass of the **driven part**, locations where the **drive** can be installed and shall include details of whether the **drive** is suitable only for balanced driven vertical parts.

They shall state that the installer shall check that the temperature range marked on the **drive** is suitable for the location.

They shall state that the drive

- cannot be used when the wicket door is open (for **drives** that are constructed so the **drive** can only operate when the wicket door is closed); or
- cannot be used when the wicket door is closed (for **drives** that are constructed so the **drive** can only operate when the wicket door is open or removed).

The instructions shall include the substance of the following:

- the necessary information for safe handling of a **drive** weighing more than 20 kg. This information shall describe how to use the handling means, such as hooks and ropes;
- vertical doors and gates need an anti-drop feature or device;
- before installing the drive, check that the driven part is in good mechanical condition, opens and closes properly and correctly balanced where applicable;
- information if a hazardous part of the **drive** is intended to be installed at a height of at least 2,5 m above floor level or other access level;
- except for **horizontally moving pedestrian doors**, ensure that entrapment between the driven part and the surrounding fixed parts due to the opening movement of the driven part is avoided;
- for **horizontally moving pedestrian doors**, ensure that entrapment between the driven part and the surrounding fixed parts due to the movement of the driven part is avoided. This can be achieved if the relevant distance does not exceed 8 mm. However, the following distances are considered sufficient to avoid entrapments for the parts of the body identified:
  - for fingers, a distance greater than 25 mm;
  - for feet, a distance greater than 50 mm;
  - for heads, a distance greater than 200 mm; and
  - for the whole body, a distance greater than 500 mm.

If these distances cannot be achieved, safeguarding devices shall be provided;

- details of the maximum allowed distance from the wall that is parallel to the sliding movement to the outside of horizontally sliding **driven parts**;
- details for the installation of the **drive** and its associated components, including details of relevant accessories required for alternate modes of operation;
- that the actuating member of a **biased-off switch** is to be located within direct sight of the **driven part** but away from moving parts. Unless it is key operated, it is to be installed at a minimum height of 1,5 m and not accessible to the public;
- details on how to set controls;
- after installation, ensure that the mechanism is properly adjusted and that the protection system and any manual release function correctly;
- permanently fix the label concerning the manual release, adjacent to its actuating member.

**7.101 Drives** having a manual release shall be supplied with a label describing how to use the release unless the information is already marked on the **drive**.

*Compliance is checked by inspection.*

## **8 Protection against access to live parts**

This clause of Part 1 is applicable except as follows.

## 8.2 Addition:

**Basic insulation** and parts separated from **live parts** by **basic insulation** may be touched during adjustment, if a **tool** is needed to gain access to the adjustment means.

## 9 Starting of motor-operated appliances

This clause of Part 1 is not applicable.

## 10 Power input and current

This clause of Part 1 is applicable except as follows.

### 10.1 Modification:

*Instead of determining the mean value, the maximum value of power input is determined, the effect of inrush currents being ignored.*

## 11 Heating

This clause of Part 1 is applicable except as follows.

### 11.7 Replacement:

**Drives** for continuous operation are operated for consecutive **cycles** until steady conditions are established.

**Drives** not for continuous operation are operated as follows:

**Drives** for gates for one household and horizontally moving garage doors for one household are operated without rest periods for three cycles or the **rated number of operating cycles**, whichever is longer.

**Drives** for **windows** drives are operated without rest periods for the **rated number of operating cycles**.

Other **drives** are operated without rest periods for the **rated number of operating cycles** but for not less than five **cycles** of operation.

## 12 Void

## 13 Leakage current and electric strength at operating temperature

This clause of Part 1 is applicable **except as follows**.

### 13.3 Addition:

*In Table 4, add the following to table footnote a:*

*The test voltage for 600 V multi-phase appliances is that specified for a **working voltage** > 250 V, where U is taken as the **rated voltage**.*

## 14 Transient overvoltages

This clause of Part 1 is applicable.

## 15 Moisture resistance

This clause of Part 1 is applicable except as follows.

### 15.1.2 Addition:

*Tubular **drives** are installed in a tube that is open at both ends and has the largest diameter specified in the instructions. The tube has a length twice that of the motor and is mounted on a support as in normal use. The support is rotated at a speed of 1 r/min.*

## 16 Leakage current and electric strength

This clause of Part 1 is applicable **as follows**.

### 16.3 In Table 7, add the following to table footnote a:

*The test voltage for 600 V multi-phase appliances is that specified for a **working voltage** > 250 V, where U is taken as the **rated voltage**.*

## 17 Overload protection of transformers and associated circuits

This clause of Part 1 is applicable.

## 18 Endurance

This clause of Part 1 is not applicable.

## 19 Abnormal operation

This clause of Part 1 is applicable except as follows.

### 19.1 Addition:

*Compliance is also checked by the test of 19.101.*

### 19.11.2 Addition:

*If the **drive** can be operated when any of the fault conditions are simulated, the applicable tests of BB.20.104, BB.20.107, CC.20.105, DD.20.104 and DD.20.107 are carried out, the **drive**, however, being supplied at **rated voltage**.*

*Either the **drive** continues to fulfill the requirements, or, after a maximum of one **cycle** of operation, it shall stop with the **driven part** in a safe position, or the **drive** shall change to a **biased-off switch** mode of operation.*

### 19.11.4.8 Replacement:

*The **drive** is supplied at **rated voltage** and operated under **normal operation**. After approximately 60 s, the power supply voltage is reduced to a level such that the **drive** ceases*

*to respond to user inputs or parts controlled by the programmable component cease to operate, whichever occurs first. This value of supply voltage is recorded. The **drive** is supplied at **rated voltage** and operated under **normal operation**. The voltage is then reduced to a value of approximately 10 % less than the recorded voltage. It is held at this value for approximately 60 s and then increased to **rated voltage**. The rate of decrease and increase of the power supply voltage is to be approximately 10 V/s.*

*The **drive** shall either continue to move in the same direction of movement in its operating **cycle** at which the voltage decrease occurred or a manual operation shall be required to restart it.*

**19.13 Addition:**

*During the test of 19.101, the winding temperature shall not exceed the values specified in 19.9.*

**19.101 Drives**, other than those for continuous operation, are supplied at **rated voltage** and operated continuously under **normal operation**.

## **20 Stability and mechanical hazards**

This clause of Part 1 is replaced by the following annexes.

Annex BB Drives for windows.

Annex CC Drives for pedestrian doors.

Annex DD Drives for horizontally and vertically moving doors, horizontally moving garage doors and gates.

## **21 Mechanical strength**

This clause of Part 1 is applicable.

## **22 Construction**

This clause of Part 1 is applicable except as follows.

**22.40** Not applicable.

**22.46 Addition:**

If compliance with the requirements in Clause 20 relies on the operation of a programmable **electronic circuit**, the software shall contain measures to control the fault/error conditions specified in Table R.1.

**22.101 Drives** weighing more than 20 kg shall incorporate suitable means for handling, such as hooks.

*Compliance is checked by inspection.*

**22.102** All controls supplied with the **drive** shall be marked to indicate the functions in the same way.

When the **drive** is provided with a dedicated stop button, that stop button shall be clearly identifiable.

*Compliance is checked by inspection.*

**22.103** When several modes of operation can be selected by the user, the selected mode shall be clearly indicated.

*Compliance is checked by inspection.*

**22.104** It shall only be possible to make adjustments that could affect compliance with this standard by means of a **tool** or by use of a code.

*Compliance is checked by inspection.*

**22.105** A **drive** for a door or gate incorporating a wicket door shall be constructed so that the **drive**

- cannot be operated when the wicket door is open (for **drives** that are constructed so the **drive** can only operate when the wicket door is closed); or
- cannot be operated when the wicket door is closed (for **drives** that are constructed so the **drive** can only operate when the wicket door is open or removed).

*Compliance is checked by inspection.*

**22.106** **Drives** shall be supplied with all associated components necessary for compliance with this standard for the defined mode of operation. Components required for alternative modes of operation may be delivered separately provided they are listed in the instructions.

*Compliance is checked by inspection.*

**22.107** Controls shall not be capable of overriding an **entrapment protection system** unless they can only activate the **drive** in sight of the **driven part**.

*Compliance is checked by test.*

## **23 Internal wiring**

This clause of Part 1 is applicable.

## **24 Components**

This clause of Part 1 is applicable except as follows.

### **24.1.3** *Addition:*

*If a switch is used to disconnect the **drive** when the manual release is operated, the switch is tested for 300 **cycles** of operation.*

## **25 Supply connection and external flexible cords**

This clause of Part 1 is applicable except as follows.

### **25.5** *Modification:*

**Type Z attachment** is allowed for separate power supplies for indoor use for **drives** having a **rated power input** not exceeding 100 W.

**25.7 Addition:**

The **supply cord** of **drives** for outdoor use shall be polychloroprene sheathed and not be lighter than ordinary polychloroprene sheathed flexible cord (code designation 60245 IEC 57).

## 26 Terminals for external conductors

This clause of Part 1 is applicable.

## 27 Provision for earthing

This clause of Part 1 is applicable.

## 28 Screws and connections

This clause of Part 1 is applicable.

## 29 Clearances, creepage distances and solid insulation

This clause of Part 1 is applicable **except as follows**.

**29.1 Addition:**

*For a **rated voltage** > 300 V and ≤ 346 V, the rated impulse voltage is for*

- overvoltage category I: 2 500 V;*
- overvoltage category II: 4 000 V;*
- overvoltage category III: 6 000 V.*

**29.3.4 Addition:**

*For a **rated voltage** > 300 V and ≤ 346 V, the minimum thickness for accessible parts of **reinforced insulation** consisting of a single layer is for*

- overvoltage category I: 0,6 mm;*
- overvoltage category II: 1,2 mm;*
- overvoltage category III: 2,0 mm.*

## 30 Resistance to heat and fire

This clause of Part 1 is applicable except as follows.

**30.2 Addition:**

*For **drives** operated by a **biased-off switch**, 30.2.2 is applicable.*

*For other **drives**, 30.2.3 is applicable.*

## 31 Resistance to rusting

This clause of Part 1 is applicable except as follows.

*Addition:*

*For parts intended to be installed outdoors, compliance is checked by the salt mist test of IEC 60068-2-52, severity 2 being applicable.*

*Before the test, coatings are scratched by means of a hardened steel pin, the end of which has the form of a cone with an angle of 40°. Its tip is rounded with a radius of 0,25 mm ± 0,02 mm. The pin is loaded so that the force exerted along its axis is 10 N ± 0,5 N. The scratches are made by drawing the pin along the surfaces of the coating at a speed of approximately 20 mm/s. Five scratches are made at least 5 mm apart and at least 5 mm from the edges.*

*After the test, the **drive** shall not have deteriorated to such an extent that compliance with this standard, in particular with Clauses 8 and 27, is impaired. The coating shall not be broken and shall not have loosened from the metal surface.*

## 32 Radiation, toxicity and similar hazards

This clause of Part 1 is applicable except as follows.

**32.101 Drives** incorporating a laser shall be constructed so that they provide adequate protection from laser radiation.

*Compliance is checked by the following test.*

***Detachable parts** are removed. Any **accessible controls** are adjusted to give the highest laser radiation even if a tool is required to make the adjustment. If the control is inaccessible, it is also adjusted to give the highest laser radiation unless its actuating member is adequately locked in position.*

NOTE Solder or sealing compound is considered to provide adequate locking.

*The **drive** is supplied at **rated voltage** and operated under **normal operation**. The laser radiation is measured in accordance with 5.2 of IEC 60825-1:2014 and the accessible emission level shall not exceed the limits for a Class 1 laser product specified in Table 3 of that standard for an emission duration of 100 s.*

*The test is repeated but under the conditions specified in Clause 19 and the laser radiation measured again. The accessible emission level shall not exceed five times the limits specified for Class I for wavelengths of 400 nm to 700 nm. For other wavelengths, it shall not exceed the limits for a Class 3R laser product as specified in Table 6 of IEC 60825-1:2014.*

*If compliance with IEC 60825-1 relies on the operation of an interlock, this interlock shall be of the fail-safe type or be tested for 30 000 cycles of operation under the conditions of 24.1.4.*

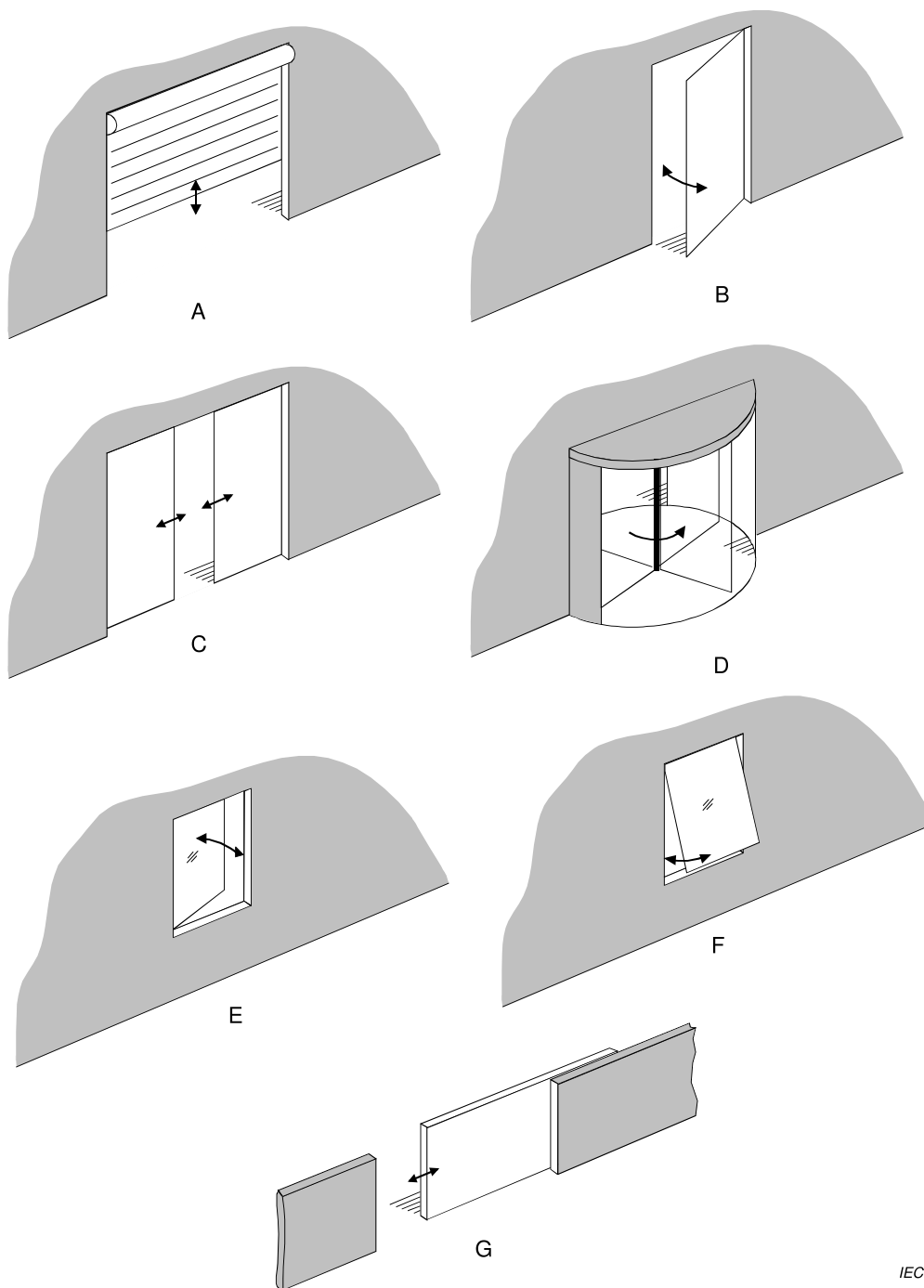

**Key**

- A rolling door
- B horizontally swinging door
- C horizontally sliding door
- D revolving door
- E vertically hinged **window** (horizontally moving)
- F horizontally hinged **window** (vertically moving)
- G horizontally sliding gate

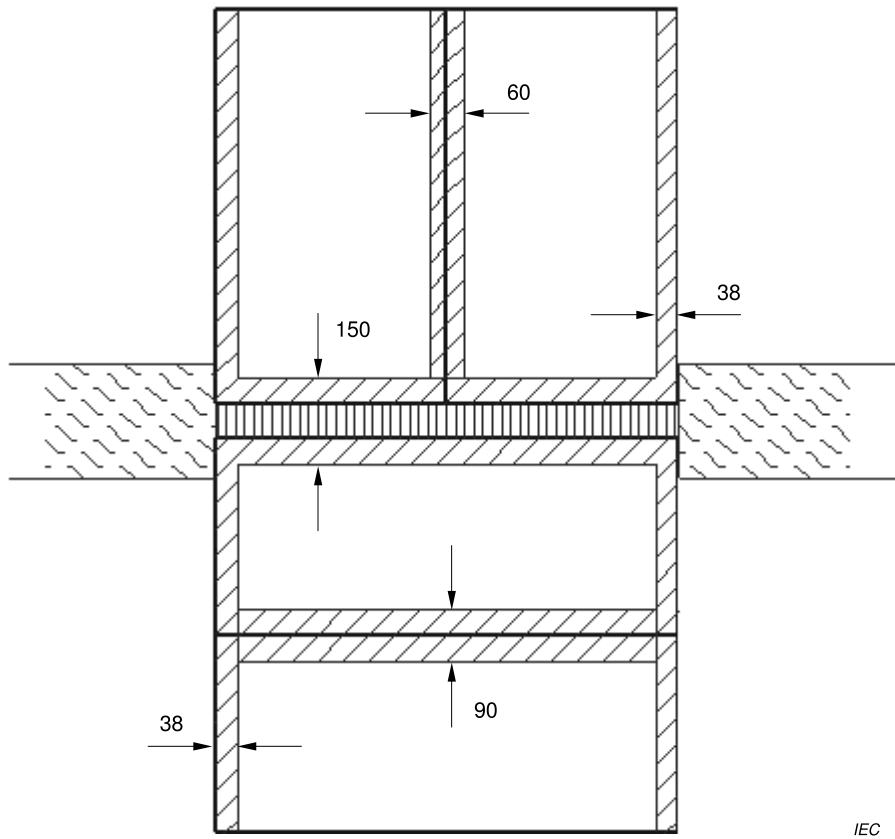

**Figure 101 – Examples of driven parts**

*Dimensions in millimetres*



IEC

**Key**

-  threshold
-  inactive area
-  wall

**Figure 102 – Inactive floor areas of pressure-sensitive pads**

## **Annexes**

The annexes of Part 1 are applicable except as follows.

## **Annex R** (normative)

### **Software evaluation**

This annex of Part 1 is applicable except as follows:

#### **R.2.2.5** *Addition:*

For other programmable **electronic circuits** with functions requiring software incorporating measures to control the fault/error conditions specified in Table R.1, detection of a fault/error shall occur within one cycle of operation if compliance with Clause 20 is impaired.

#### **R.2.2.9** *Addition:*

For other programmable electronic circuits, the software and safety-related hardware under its control shall be initialized and shall terminate within one cycle of operation if compliance Clause 20 is impaired.

## Annex AA (normative)

### Drives for powered pedestrian doors used in emergency routes and emergency exits

The following additions to this standard are applicable for **drives** for doors used in emergency routes and emergency exits.

NOTE In many countries, additional requirements are specified by national authorities.

#### 7 Marking and instructions

7.7 Where terminals for connection to a fire alarm system are provided, these shall be identified.

7.12 The instructions shall include the substance of the following:

Ensure that controls that can be set for a locked position are only activated when there are no other persons in the room.

7.12.1 The instructions shall include the substance of the following:

Unless the system allows break out in the escape direction, **drives** are to be connected so that doors either open in the escape direction or provide a clear escape path.

NOTE Sliding doors are considered to provide a clear escape path.

#### 20 Stability and mechanical hazards

This clause of Part 1 is replaced by the requirements and tests specified in Annex CC.

#### 22 Construction

22.108 **Drives** shall be constructed so that they cannot be put into a locked mode that prevents the door from being opened from the inside unless a night security position is selected by a key, code system or similar means.

*Compliance is checked by inspection.*

22.109 **Drives** shall be constructed so that they operate break-out doors or automatic-opening doors.

*Compliance is checked by inspection.*

22.110 **Drives** for break-out doors shall be constructed so that they release the door in the event of an emergency.

*Compliance is checked by the following test.*

*The **drive** is installed with a door and supplied at **rated voltage**. A force of 220 N is applied at a height of  $1\text{ m} \pm 10\text{ mm}$  to the leading edge of the door in the break-out direction. The door shall become released from the **drive**.*

**22.111 Drives** for automatic-opening doors shall be constructed so that the door opens automatically if the power supply fails and the system has not been deliberately selected to be in the security position.

*Compliance is checked by the test of 22.111.1, and if a battery is required, also with 22.111.2 and 22.111.3.*

**22.111.1** *The **drive** is installed with a door and supplied at **rated voltage**, any battery being fully charged. The supply is disconnected and the door shall start to open immediately at a speed of at least 200 mm/s. It shall then remain open.*

**22.111.2** *The **drive** is installed with a door and supplied at **rated voltage**, the battery being fully charged. The battery is discharged at a rate of approximately 25 % of its rated capacity per hour. The door shall start to open within 4 h, the opening speed being at least 200 mm/s. It shall then remain open.*

**22.111.3** *The **drive** is installed with a door and supplied at **rated voltage**. The battery is disconnected. The door shall start to open within 30 min, the opening speed being at least 200 mm/s. It shall then remain open.*

## Annex BB (normative)

### Drives for windows

#### 20 Stability and mechanical hazards

This clause of Part 1 is applicable except as follows.

**20.1** Not applicable

**20.2** *Addition:*

Moving parts of **drives** intended to be installed at a height of at least 2,5 m above the ground or other access level are considered to be positioned so to provide adequate protection against personal injury in normal use.

NOTE 101 Stairs and terraces are examples of access levels. Surfaces not normally used for standing on, such as window-sills, and movable equipment such as ladders, are not considered to be access levels.

**BB.20.101** **Drives** for **windows** shall operate so that the movement of the **window** is not likely to cause an injury.

*Compliance is checked as follows:*

- **drives** controlled by a **biased-off switch**, by the requirement and test of BB.20.104;
- **drives** incorporating an **entrapment protection system**, by the relevant requirement and tests of BB.20.107 and BB.20.109.

*Other **drives** are subjected to the following test.*

*The **drive** is installed with a **window** and supplied at the most unfavourable voltage between 0,94 and 1,06 times **rated voltage**. The **drive** is adjusted for the highest opening and closing forces, if the adjustment is mentioned in the instructions.*

*The **drive** is operated to open the **window**. The speed of the leading edge shall not exceed 50 mm/s.*

*When fully open, the gap between counter opposing edges shall not exceed 200 mm, unless the opening movement is controlled by a smoke control system. The **drive** is then operated to close the **window** and the speed of the leading edge shall not exceed 15 mm/s.*

*If the **drive** is controlled by a programmable **electronic circuit**, the software shall contain measures to control the fault/error conditions specified in Table R.1 and is evaluated in accordance with the relevant requirements of Annex R.*

**BB.20.102** Where a manual release or **reversible drive** is provided, it shall be easy to operate. Operation of the release shall not give rise to a hazard such as kickback or unexpected operation of the **drive**.

The **drive** shall not create any hazard when the manual release is activated.

Operation of a **reversible drive** used as a means for a manual release shall not give rise to a hazard.

*Compliance is checked by the following test.*

*Automatic operation of **automatic drives** is disabled.*

*The **drive** is installed with a **window** and supplied at the most unfavourable voltage between 0,94 and 1,06 times **rated voltage**. The **drive** is adjusted for the highest opening and closing forces, if such adjustment is mentioned in the instructions. The manual release is operated when the **window** has stopped at each terminal position, in turn. The release or **reversible drive** shall be operable with a force not exceeding 220 N or a torque not exceeding 1,6 Nm. The force is applied as stated in the instructions.*

*The test is repeated with the power supply interrupted.*

*When the manual release has been activated, the power supply is then restored and the **drive** activated. The **drive** shall not move, or if the **drive** moves, all requirements of this standard shall be met.*

**BB.20.103** A mechanical fault in the **drive** shall not result in a hazardous operation.

*Compliance is checked by inspection and, if necessary, by test.*

*The inspection shall evaluate which parts can affect the safety of operation and whether they are likely to break or become loose. These parts may be part of the **drive** or used for connecting the **drive** to the **window**.*

NOTE Examples of parts that are evaluated are screws, pins, shafts, wheels, chains and supporting parts.

*If inspection cannot determine whether the **drive** will continue to operate normally or stop its movement when the part has failed, the following test is carried out.*

*The **drive** is installed with a **window**, the force exerted by the **drive** being adjusted to its highest value in accordance with the instructions. The **drive** is supplied at the most unfavourable voltage between 0,94 and 1,06 times **rated voltage**.*

*The faults are introduced one at a time and the **drive** is operated as in normal use.*

*Unless the **drive** and the **window** continue to operate normally, all of the following conditions shall be fulfilled:*

- the **drive** shall stop operating at least by the end of the **cycle** of movement;*
- further operation shall not be possible;*
- the speed of the **window** shall not increase by more than 20 %.*

**BB.20.104 Drives** controlled by a **biased-off switch** shall stop when its actuating member is released.

*Compliance is checked by the following test.*

The **drive** is installed with a **window** and supplied at the most unfavourable voltage between 0,94 and 1,06 times **rated voltage**. It is operated to close the **window**.

When the actuating member is released, the leading edge of the **window** shall stop within a distance of 20 mm.

*The test is repeated during the opening movement of the **window**.*

*The requirement for the **window** to stop within the specified distance only applies if the closing force exerted by the **window** exceeds 150 N, as measured in BB.20.107.2.*

*If the **drive** is controlled by a programmable **electronic circuit**, the software shall contain measures to control the fault/error conditions specified in Table R.1 and is evaluated in accordance with the relevant requirements of Annex R.*

**BB.20.105** During the movement of the **drive** in either direction, the actuation of a manual control shall stop the movement if there is no separate button for the stop function.

If the **drive** has a single button for controlling the movement, further actuation shall reverse the direction of movement.

If the **drive** has three buttons for controlling the movement, one button shall be a stop button.

These requirements do not apply to controls affecting automatic modes of operation.

Any button that has a stop function shall not require a key to stop the **drive**.

*Compliance is checked by a manual test.*

NOTE The test can be carried out without a **window**.

**BB.20.106 Drives** shall not restart automatically after the movement has stopped unintentionally.

NOTE 1 Unintentional stopping may be caused by interruption of the power supply or by operation of a **thermal cut-out**.

*Compliance is checked by the following tests.*

*The **drive** is supplied at **rated voltage** and operated under **normal operation**. The supply is then interrupted. After the supply is restored, the **drive** shall not restart automatically. However, **automatic drives** may re-start, provided that they function as in normal use.*

*The **drive** is operated again and operation of the **thermal cut-out** is simulated. After the fault condition has been removed, the **drive** shall not restart automatically. However, **automatic drives** may re-start, provided that they function as in normal use.*

NOTE 2 The test can be carried out without a **window**.

*If the **drive** is controlled by a programmable **electronic circuit**, the software shall contain measures to control the fault/error conditions specified in Table R.1 and is evaluated in accordance with the relevant requirements of Annex R.*

**BB.20.107** An **entrapment protection system** in a **drive** for **windows** shall be operated to reduce the likely hood of injury to the user.

*For **drives** incorporating an **entrapment protection system** with sensing devices that prevent the **window** from coming into contact with a person, compliance is checked by the test specified in BB.20.107.1.*

*Obstacles used in the following tests shall be made of materials and colours to simulate the most unfavourable conditions. In case of doubt the obstacles shall be made of un-planed wood and painted white*

*For **drives** incorporating an **entrapment protection system** that allows the **window** to contact a person, compliance is checked by the relevant tests specified in BB.20.107.2.*

NOTE 3 In one direction of travel of the **window**, BB.20.107.1 can be met and BB.20.107.2 can be met in the opposite direction of travel.

*If the **drive** is controlled by a programmable **electronic circuit**, the software shall contain measures to control the fault/error conditions specified in Table R.1 and is evaluated in accordance with the relevant requirements of Annex R.*

**BB.20.107.1** The **drive** is installed with a **window**, the force exerted by the **drive** being adjusted to its highest value in accordance with the instructions. The **drive** is supplied at the most unfavourable voltage between 0,94 and 1,06 times **rated voltage**.

*For horizontally moving **windows**, the test of BB.20.107.1.1 is carried out.*

*For vertically moving **windows**, the test of BB.20.107.1.2 is carried out.*

**BB.20.107.1.1** *An obstacle having dimensions of approximately 25 mm × 100 mm × 300 mm, with three sides (one in each dimension) having a reflective surface, obtained by use of mirrors, fine grained stainless steel or white-gloss paint, and the other three sides being non-reflective surfaces painted dull-black, is placed at any place in the path of the leading edge and plane of the **window** and in the most unfavourable dimension. The tests with this obstacle shall be made using the non-reflective and reflective sides in turn.*

*The **drive** is operated to close the **window** from the fully open position and from a 300 mm gap. If the **window** moves, it shall stop or reverse its movement without contacting the obstacle.*

**BB.20.107.1.2** *An obstacle having dimensions of approximately 25 mm × 100 mm × 300 mm is placed at any place in the path of the leading edge along its 300 mm length across the **window** opening.*

*The **drive** is operated to close the **window** from heights of 100 mm, 1 000 mm and the fully open position of the **window**. The **window** shall not move or shall only move in the opening direction.*

**BB.20.107.2** *The **drive** is installed with a **window**. The force exerted by the **drive** is adjusted to the highest value if the force can be adjusted by the user during use or **user maintenance**. Otherwise, the force should be adjusted according to the installation instructions. The **drive** is supplied at the most unfavourable voltage between 0,94 and 1,06 times **rated voltage**.*

The **drive** is operated to close the **window** from the fully open position. The forces between the leading edge and counter opposing edges shall not exceed

- 150 N during the first 5 s after the force has exceeded 25 N;
- 25 N thereafter;

or

- 400 N during the first 0,75 s after the force has exceeded 150 N;
- 150 N during a further period of 4,25 s;
- 25 N thereafter;

However, after 0,75 s, peaks lower than 400 N are allowed, if

- they are decreasing from one to the other, and
- the period of oscillation is  $\leq 1$  s, and
- the average force calculated over the remaining period of 4,25 s is  $\leq 150$  N.

The force is measured by means of an instrument that incorporates a rigid plate having a diameter of 80 mm and a spring having a ratio of 500 N/mm  $\pm$  50 N/mm. The spring acts on a sensing element that is connected to an amplifier having a rise and fall time not exceeding 5 ms.

For vertically moving **windows**, the force is measured on the leading edge of the **windows** when the dimension of the gap is

- 50 mm;
- 300 mm;
- 500 mm.

The force is measured at the following locations:

- in the centre of the leading edge;
- 200 mm from each end of the leading edge if this edge is longer than 800 mm.

For horizontally moving **windows**, the force is measured on the leading edge of the **window**, at the following heights, when the dimension of the gap is 50 mm and 500 mm:

- 50 mm;
- 300 mm from the top, for **windows** between 1,2 m and 2,5 m in height;
- 2 500 mm, for **windows** more than 2,8 m in height;
- in the centre, for **windows** not more than 2,8 m in height.

**BB.20.108 Drives** shall prevent vertically moving **windows** from closing unexpectedly.

Compliance is checked by the following test.

The **drive** is supplied at the most unfavourable voltage between 0,94 and 1,06 times **rated voltage** but is not operated. Automatic operation of **automatic drives** is disabled. It is loaded with 1,2 times the **rated load** applied for 30 min. If the **drive** is supplied with a **window**, the load is applied to the **window** and is equal to the highest force exerted by it.

*There shall be no movement except for initial removal of any play in the system. If there is creepage in the **drive**, the **window** shall not move faster than 1 mm/s.*

NOTE 1 The highest force is determined with the **window** in the most unfavourable position, the **drive** not being energized.

NOTE 2 It is to be noted that compliance with 20.108 does not necessarily cover risks due to operation of the **window**. Anti-drop or equivalent safety devices might be necessary.

*The test is repeated with the supply disconnected.*

*If the **drive** is controlled by a programmable **electronic circuit**, the software shall contain measures to control the fault/error conditions specified in Table R.1 and is evaluated in accordance with the relevant requirements of Annex R.*

**BB.20.109 Entrapment protection systems** shall provide an adequate level of protection in the event of a failure within the system installation wiring.

*The **drive** is installed with a **window** and supplied at **rated voltage**. The **drive** is operated to close the **window**. During the movement, a short circuit or open circuit is simulated in the system installation wiring.*

*Unless the system continues to operate normally, the **window** shall stop moving within one **cycle** of operation or the movement of the **window** shall only be controlled by a **biased-off switch** by the time it has completed its movement.*

## Annex CC (normative)

### Drives for pedestrian doors

#### 20 Stability and mechanical hazards

This clause of Part 1 is applicable except as follows.

**20.1** Not applicable.

**20.2** *Addition:*

Moving parts of **drives** intended to be installed at a height of at least 2,5 m above the ground or other access level are considered to be positioned so to provide adequate protection against personal injury in normal use.

NOTE 101 Stairs and terraces are examples of access levels. Surfaces not normally used for standing on, such as window-sills, and movable equipment such as ladders, are not considered to be access levels.

For **horizontally moving pedestrian doors**, moving parts including interconnecting parts of their **drives** need not be guarded if the gap between fixed and moving parts is below 8 mm, or above 25 mm, or it is at least 2 m above the ground. This also applies to the gap between parts that may move at different speeds.

**CC.20.101** Where manual release or **reversible drive** is provided it shall be easy to operate. Operation of the release shall not give rise to a hazard such as kickback or unexpected operation of the **drive**.

The **drive** shall not create any hazard when the manual release is activated.

Operation of a **reversible drive** used as a means for a manual release shall not give rise to a hazard.

*Compliance is checked by the following test.*

*Automatic operation of **automatic drives** is disabled.*

*The **drive** is installed with a pedestrian door and supplied at the most unfavourable voltage between 0,94 and 1,06 times **rated voltage**. The **drive** is adjusted for the highest opening and closing forces, if such adjustment is mentioned in the instructions. The manual release is operated when the pedestrian door has stopped at each terminal position, in turn. The release or **reversible drive** shall be operable with a force not exceeding 220 N or a torque not exceeding 1,6 Nm. The force is applied as stated in the instructions.*

*The test is repeated with the power supply disconnected.*

*When the manual release has been activated, the power supply is then restored and the **drive** activated. The **drive** shall not move, or if the **drive** moves, all requirements of this standard shall be met.*

**CC.20.102** A mechanical fault in the **drive** shall not result in a hazardous operation.

*Compliance is checked by inspection and, if necessary, by test.*

*The inspection shall evaluate which parts can affect the safety of operation and whether they are likely to break or become loose. These parts may be part of the **drive** or used for connecting the **drive** to the pedestrian door.*

NOTE Examples of parts that are evaluated are screws, pins, shafts, wheels, chains and supporting parts.

*If inspection cannot determine whether the **drive** will continue to operate normally or stop its movement when the part has failed, the following test is carried out.*

*The **drive** is installed with a pedestrian door, the force exerted by the **drive** being adjusted to its highest value in accordance with the instructions. The **drive** is supplied at the most unfavourable voltage between 0,94 and 1,06 times **rated voltage**.*

*The faults are introduced one at a time and the **drive** is operated as in normal use.*

*Unless the **drive** and the pedestrian door continue to operate normally, all of the following conditions shall be fulfilled:*

- *the **drive** shall stop operating at least by the end of the **cycle** of movement;*
- *further operation shall not be possible;*
- *the speed of the pedestrian door shall not increase by more than 20 %.*

**CC.20.103** During the movement of the **drive** in either direction, the actuation of a manual control shall stop the movement if there is no separate button for the stop function.

If the **drive** has a single button for controlling the movement, further actuation shall reverse the direction of movement.

If the **drive** has three buttons for controlling the movement, one button shall be a stop button.

These requirements do not apply to controls affecting automatic modes of operation.

Any button that has a stop function shall not require a key to stop the **drive**.

*Compliance is checked by a manual test.*

**CC.20.104 Drives** shall not restart automatically after the movement has stopped unintentionally.

NOTE 1 Unintentional stopping can be caused by interruption of the power supply or by operation of a **thermal cut-out**.

*Compliance is checked by the following tests.*

*The **drive** is supplied at **rated voltage** and operated under **normal operation**. The supply is then interrupted. After the supply is restored, the **drive** shall not restart automatically. However, **automatic drives** may re-start, provided that they function as in normal use.*

*The **drive** is operated again and operation of the **thermal cut-out** is simulated. After the fault condition has been removed, the **drive** shall not restart automatically. However, **automatic drives** may re-start, provided that they function as in normal use.*

NOTE 2 The test can be carried out without a pedestrian door.

*If the **drive** is controlled by a programmable **electronic circuit**, the software shall contain measures to control the fault/error conditions specified in Table R.1 and is evaluated in accordance with the relevant requirements of Annex R.*

**CC.20.105 Drives** shall incorporate an **entrapment protection system** that reduces the risk of injury when the pedestrian door moves or shall be adjustable to control the energy of the movement of the pedestrian door.

NOTE In one direction of travel of the pedestrian door, CC.20.105.1 can be met and CC.20.105.2 can be met in the opposite direction of travel.

For **drives**, incorporating an **entrapment protection system** that allows the pedestrian door to contact a person, compliance is checked by the relevant tests specified in CC.20.105.2.

If the **drive** is controlled by a programmable **electronic circuit**, the software shall contain measures to control the fault/error conditions specified in Table R.1 and is evaluated in accordance with the relevant requirements of Annex R.

**CC.20.105.1** For **drives** incorporating an **entrapment protection system** with sensing devices that prevent the pedestrian door from coming into contact with a person, compliance is checked by the following relevant tests.

The **drive** is installed with a pedestrian door, the force exerted by the **drive** being adjusted to its highest value in accordance with the instructions. The **drive** is supplied at the most unfavourable voltage between 0,94 and 1,06 times **rated voltage**.

If the sensing devices are other than pressure sensitive pads, the test specified in CC.20.105.1.1 is applied.

If the sensing devices are pressure sensitive pads, the test specified in CC.20.105.1.2 is applied.

For pedestrian doors, an **entrapment protection system** with sensing devices that continuously adapt to environmental changes shall detect a stationary obstacle for at least 30 s.

**CC.20.105.1.1** The reference bodies for the tests shall be in accordance with Annex FF.

For **horizontally moving pedestrian doors**, the **drive** is operated to open or close the **door**. For **drives** for **horizontally moving pedestrian doors** other than revolving doors, tests are carried out using the reference body positioned in the moving plane of the pedestrian door as shown in Figures EE.1 to EE.5 of Annex EE.

The reference body CA is detected in all positions of the travel area of the doorset leaves.

For **drives** for revolving doors, tests are carried out in accordance with Annex GG using the reference body positioned as shown in Figures EE.6 to EE.8 of Annex EE.

**CC.20.105.1.2** If the **entrapment protection system** incorporates a pressure-sensitive floor pad, a mass of 15 kg  $\pm$  0,5 kg having a diameter of approximately 60 mm is used.

The following inactive floor pad areas are excluded from this requirement:

- the last 38 mm on each side of the pedestrian door opening width;
- 60 mm along the junction of floor pads joined together side-by-side with the longest dimension perpendicular to the pedestrian door opening;
- 90 mm along the junction of floor pads joined together side-by-side with the longest dimension parallel to the pedestrian door opening;
- 150 mm across the junction of floor pads meeting at the threshold.

NOTE The inactive floor areas of pressure sensitive pads are shown in Figure 102.

**CC.20.105.2 Entrapment protection systems** that allow the pedestrian door to contact a person shall only be used to reduce the risk of injury for:

- the opening movement of a sliding door with the leave(s) moving along a plain part and the distance between the front surface of the leave and the fixed side screen or wall is more than 100 mm and less or equal to 150 mm;
- the opening and closing movement of a balanced door;
- the opening movement of a folding door;
- the closing movement of a folding door only in combination with an **entrapment protection system** with sensing devices that prevent the pedestrian door from coming into contact with a person installed at the outer side of the door;
- the movement of revolving doors in combination with the peripheral speed which shall not exceed 1 000 mm/s for a door with a diameter up to 3 000 mm and shall not exceed 750 mm/s for a door with a diameter over 3 000 mm.

For **drives** incorporating an **entrapment protection system** that allows the pedestrian door to contact a person, compliance is checked by the following relevant tests.

The **drive** is installed with a pedestrian door. The force exerted by the **drive** is adjusted to the highest value if the force can be adjusted by the user during use or **user maintenance**. Otherwise, the force is adjusted according to the installation instructions. The **drive** is supplied at the most unfavourable voltage between 0,94 and 1,06 times **rated voltage**.

The **drive** is operated to close and open the pedestrian door from the fully open and fully closed positions. The forces between the leading edge and counter opposing edges shall not exceed the values stated in Annex HH when measured at points (F) according to Annex II.

The force is measured by means of an instrument that incorporates a rigid plate having a diameter of 80 mm and a spring having a ratio of 500 N/mm  $\pm$  50 N/mm. The spring acts on a sensing element that is connected to an amplifier having a rise and fall time not exceeding 5 ms.

**CC.20.105.3 Drives** adjustable to control the energy of the movement of a pedestrian door, shall be in compliance with Annex JJ or Annex LL.

**Drives** adjustable to control the energy of the movement of a pedestrian door shall only be used to reduce the risk of injury for:

- the opening and closing movement of a sliding door when the movement is in accordance with Annex JJ;
- the opening and closing movement of a swing door when the movement is in accordance with Annex JJ;
- the opening and closing movement of a revolving door when the movement is in accordance with Annex JJ;
- the opening movement of a swing door when the movement is in accordance with Annex LL and sufficient safety distances are provided (see Figure CC.1);
- the closing movement of a swing door when the movement is in accordance with Annex LL.

**CC.20.106 Entrapment protection systems** shall provide an adequate level of protection in the event of a failure within the system installation wiring.

Compliance is checked by the following test.

The **drive** is installed with a pedestrian door and supplied at **rated voltage**. The **drive** is operated to close the pedestrian door. During the movement, a short circuit or open circuit is simulated in the system installation wiring.

Unless the system continues to operate normally, the pedestrian door shall stop moving within one **cycle** of operation or the movement of the pedestrian door shall only be controlled by a **biased-off switch** by the time it has completed its movement.

The test is repeated during the opening movement of the pedestrian door.

If the **drive** is controlled by a programmable **electronic circuit**, the software shall contain measures to control the fault/error conditions specified in Table R.1 and is evaluated in accordance with the relevant requirements of Annex R.

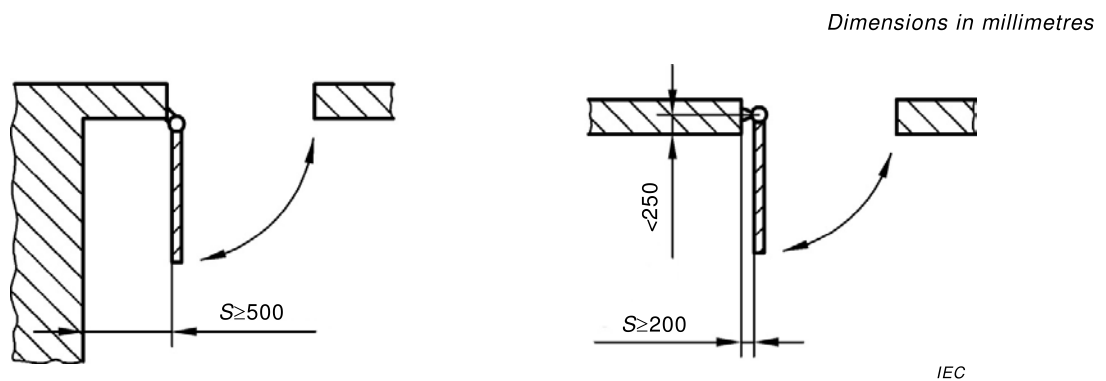

**Key**

S safety distance

**Figure CC.1 – Safety distances for opening movement of swing door**

## Annex DD (normative)

### Drives for horizontally and vertically moving doors and gates

NOTE Pedestrian doors are covered in Annex CC.

#### 20 Stability and mechanical hazards

This clause of Part 1 is applicable except as follows.

**20.1** Not applicable.

**20.2** *Addition:*

Moving parts of **drives** intended to be installed at a height of at least 2,5 m above the ground or other access level are considered to be positioned so to provide adequate protection against personal injury in normal use.

NOTE 101 Stairs and terraces are examples of access levels. Surfaces not normally used for standing on, such as window-sills, and movable equipment such as ladders, are not considered to be access levels.

**DD.20.101** **Drives** shall prevent vertically moving **driven parts** from closing unexpectedly.

*Compliance is checked by the following test.*

*The **drive** is supplied at the most unfavourable voltage between 0,94 and 1,06 times **rated voltage** but is not operated. Automatic operation of **automatic drives** is disabled. It is loaded with 1,2 times the **rated load** applied for 30 min. If the **drive** is supplied with a **driven part**, the load is applied to the **driven part** and is equal to the highest force exerted by it.*

*There shall be no movement except for initial removal of any play in the system.*

NOTE 1 The highest force is determined with the **driven part** in the most unfavourable position, the **drive** not being energized.

*The test is repeated with the supply disconnected.*

*If the **drive** is controlled by a programmable **electronic circuit**, the software shall contain measures to control the fault/error conditions specified in Table R.1 and is evaluated in accordance with the relevant requirements of Annex R.*

**DD.20.102** Where a manual release or **reversible drive** is provided, it shall be easy to operate. Operation of the release shall not give rise to a hazard such as kickback or unexpected operation of the **drive**.

The **drive** shall not create any hazard when the manual release is activated.

Operation of a **reversible drive** used as a means for a manual release shall not give rise to a hazard.

*Compliance is checked by the following test.*

*Automatic operation of **automatic drives** is disabled.*

The **drive** is installed with a **driven part** and supplied at the most unfavourable voltage between 0,94 and 1,06 times **rated voltage**. The **drive** is adjusted for the highest opening and closing forces, if such adjustment is mentioned in the instructions. The manual release is operated when the **driven part** has stopped at each terminal position, in turn. The release or **reversible drive** shall be operable with a force not exceeding 220 N or a torque not exceeding 1,6 Nm. The force is applied as stated in the instructions.

The test is repeated with the power supply interrupted.

When the manual release has been activated, the power supply is then restored and the **drive** activated. The **drive** shall not move, or if the **drive** moves, all requirements of this standard shall be met.

**DD.20.103** A mechanical fault in the **drive** shall not result in a hazardous operation.

Compliance is checked by inspection and, if necessary, by test.

**Drives** for balanced vertically **driven parts** are not tested.

NOTE 1 Balanced vertically **driven parts** can utilise springs, counterweights or other means to support the mass of the **driven part**.

The inspection shall evaluate which parts can affect the safety of operation and whether they are likely to break or become loose. These parts may be part of the **drive** or used for connecting the **drive** to the **driven part**.

NOTE 2 Examples of parts that are evaluated are screws, pins, shafts, wheels, chains and supporting parts.

If inspection cannot determine whether the **drive** will continue to operate normally or stop its movement when the part has failed, the following test is carried out.

The **drive** is installed with a **driven part**, the force exerted by the **drive** being adjusted to its highest value in accordance with the instructions. The **drive** is supplied at the most unfavourable voltage between 0,94 and 1,06 times **rated voltage**.

The faults are introduced one at a time and the **drive** is operated as in normal use.

Unless the **drive** and the **driven part** continue to operate normally, all of the following conditions shall be fulfilled:

- the **drive** shall stop operating at least by the end of the **cycle** of movement;
- further operation shall not be possible;
- the speed of the **driven part** shall not increase by more than 20 % or it shall stop within 300 mm.

NOTE 3 For vertically moving doors, anti-drop or equivalent safety devices might be necessary.

**DD.20.104** **Drives** controlled by a **biased-off switch** shall stop when the actuating member is released.

Compliance is checked by the following test.

The **drive** is installed with a **driven part** and supplied at the most unfavourable voltage between 0,94 and 1,06 times **rated voltage**. It is operated to close the **driven part**.

When the actuating member is released, the leading edge of the **driven part** shall stop within a distance of

- for door or gate other than swing type, 50 mm when the opening gap does not exceed 500 mm except for horizontally swinging **driven parts** which shall stop within 100 mm;
- for swing type door or gate, 100 mm when the opening gap does not exceed 500 mm;
- for any type of door or gate, 100 mm when the opening gap exceeds 500 mm. The test is repeated during the opening movement of the **driven part**.

The requirement for the **driven part** to stop within the specified distance only applies if the closing force exerted by the **driven part** exceeds 150 N, as measured in DD.20.107.2.1.

If the **drive** is controlled by a programmable **electronic circuit**, the software shall contain measures to control the fault/error conditions specified in Table R.1 and is evaluated in accordance with the relevant requirements of Annex R.

**DD.20.105** During the movement of the **drive** in either direction, the actuation of a manual control shall stop the movement if there is no separate button for the stop function.

If the **drive** has a single button for controlling the movement, further actuation shall reverse the direction of movement.

If the **drive** has three buttons for controlling the movement, one button shall be a stop button.

These requirements do not apply to controls operating **automatic drives**.

Any button that has a stop function shall not require a key to stop the **drive**.

*Compliance is checked by a manual test.*

NOTE The test can be carried out without a **driven part**.

If the **drive** is controlled by a programmable **electronic circuit**, the software shall contain measures to control the fault/error conditions specified in Table R.1 and is evaluated in accordance with the relevant requirements of Annex R.

**DD.20.106 Drives** shall not restart automatically after the movement has stopped unintentionally.

NOTE 1 Unintentional stopping may be caused by interruption of the power supply or by operation of a **thermal cut-out**.

*Compliance is checked by the following tests.*

The **drive** is supplied at **rated voltage** and operated under **normal operation**. The supply is then interrupted. After the supply is restored, the **drive** shall not restart automatically. However, **automatic drives** may re-start, provided that they function as in normal use.

The **drive** is operated again and operation of the **thermal cut-out** is simulated. After the fault condition has been removed, the **drive** shall not restart automatically. However, **automatic drives** may re-start, provided that they function as in normal use.

NOTE 2 The test can be carried out without a **driven part**.

**DD.20.107 Drives** not controlled by a **biased off switch** shall incorporate an **entrapment protection system** that reduces the risk of injury when the **driven part** moves.

*If the **drive** is controlled by a programmable **electronic circuit**, the software shall contain measures to control the fault/error conditions specified in Table R.1 and is evaluated in accordance with the relevant requirements of Annex R.*

*For **drives** incorporating an **entrapment protection system** with sensing devices that prevent the **driven part** from coming into contact with a person, compliance is checked by the relevant tests specified in DD.20.107.1.*

*For **drives** incorporating an **entrapment protection system** that allows the **driven part** to contact a person, compliance is checked by the tests specified in 20.107.2.*

*For **drives** incorporating an **entrapment protection system** with a non-contact sensing device that moves with the leading edge of a **driven part**, compliance is checked by the tests specified in DD.20.107.2.*

NOTE In one direction of travel of the **driven part**, DD.20.107.1 can be met and DD.20.107.2 can be met in the opposite direction of travel.

**DD.20.107.1** *The **drive** is installed with a **driven part**, the force exerted by the **drive** being adjusted to its highest value in accordance with the instructions. The **drive** is supplied at the most unfavourable voltage between 0,94 and 1,06 times **rated voltage**.*

*If the sensing devices are other than pressure sensitive pads, the tests specified in DD.20.107.1.1 to DD.20.107.1.3 are applied.*

*If the sensing devices are pressure sensitive pads, the test specified in DD.20.107.1.4 is applied.*

**DD.20.107.1.1** *An obstacle having dimensions of approximately 200 mm × 300 mm × 700 mm with three sides (one in each dimension) having a reflective surface, obtained by use of mirrors, fine grained stainless steel or white-gloss paint, and the other three sides being non reflective surfaces painted dull-black, is placed on the ground at any place in the path of the leading edges and planes of the **driven part** and in the most unfavourable position. The tests with this obstacle shall be made using the non-reflective and reflective sides in turn.*

NOTE The leading edge is the edge of the **driven part** in the direction of travel, either opening or closing.

*For horizontally moving **driven parts**, the **drive** is operated to open or close the **driven part**. If the **driven part** moves, it shall stop or reverse its movement without contacting the obstacle.*

*The obstacle is then located with the 700 mm dimension positioned vertically and raised off the ground in the worst position between the ground and 300 mm below the **driven part** height or 2 500 mm, whichever is lower.*

*The **drive** is operated to close the **driven part**. If the **driven part** moves, it shall stop or reverse its movement without contacting the obstacle.*

**DD.20.107.1.2** *For vertically moving **driven parts**, the obstacle used in DD.20.107.1.1 is placed on the ground at any place in the path of the leading edge along its 300 mm length across the **driven part** opening.*

For vertically moving **driven parts**, the **drive** is operated to close the **driven part** from heights of 100 mm, 1 000 mm and the fully open position of the **driven part**. The **driven part** shall not move or shall only move in the opening direction.

**DD.20.107.1.3** For horizontally and vertically moving **driven parts**, the obstacle used in DD.20.107.1.1 is located with the 700 mm dimension positioned vertically and is moved at a speed of  $3 \text{ m/s} \pm 0,6 \text{ m/s}$ .

For both horizontally and vertically moving **driven parts**, the obstacle is moved in a straight line through the plane of the **driven part** opening at the most unfavourable angle.

The **drive** is operated to close the **driven part**. The **driven part** shall stop or reverse its movement without contacting the obstacle.

**DD.20.107.1.4** If the **entrapment protection system** incorporates a pressure-sensitive floor pad, a mass of  $15 \text{ kg} \pm 0,5 \text{ kg}$  having a diameter of approximately 60 mm is used instead of the wooden obstacle.

The mass is placed in the path of the **driven part** and the **drive** is operated, the **driven part** shall stop or reverse its movement before contacting the mass.

The following inactive floor pad areas are excluded from this requirement:

- the last 38 mm on each side of the **driven part** opening width;
- 60 mm along the junction of floor pads joined together side-by-side with the longest dimension perpendicular to the **driven part** opening;
- 90 mm along the junction of floor pads joined together side-by-side with the longest dimension parallel to the **driven part** opening;
- 150 mm across the junction of floor pads meeting at the threshold.

NOTE 1 The inactive floor areas of pressure sensitive pads are shown in Figure 102.

**DD.20.107.2** The **drive** is installed with a **driven part**. The force exerted by the **drive** is adjusted to the highest value if the force can be adjusted by the user during use or **user maintenance**. Otherwise, the force is adjusted according to the installation instructions. The **drive** is supplied at the most unfavourable voltage between 0,94 and 1,06 times **rated voltage**.

The test of DD.20.107.2.1 is applied and

- if the **drive** is intended to be used with vertically moving **driven parts** having openings in which a 50 mm tube can be inserted, the test of DD.20.107.2.2 is applied for an opening movement;
- if the **drive** is an **automatic drive**, or a **drive** that operates the **driven part** in at least one direction by a command that can be initiated via a connection to a telecommunication or communication network, the test of DD.20.107.2.3 is applied.

**DD.20.107.2.1** The **drive** is operated to close and open the **driven part** from the fully open and fully closed positions. The forces between the leading edge and counter opposing edges shall not exceed

- 150 N during the first 5 s after the force has exceeded 25 N;
- 25 N thereafter;

or

- 400 N during the first 0,75 s after the force has exceeded 150 N;
- 150 N during a further period of 4,25 s;

- 25 N thereafter;

or for vertically moving **driven parts** used as a door;

- 600 N during the first 2 s after the force has exceeded 150 N for **driven parts** that do not swing outward and meet DD.20.107.2.3;
- 400 N during the first 2 s after the force has exceeded 150 N for **driven parts** that swing outward;
- 150 N during a further period of 3 s;
- 25 N thereafter.

However, after 0,75 s, peaks lower than 400 N are allowed, if

- they are decreasing from one to the other, and
- the period of oscillation is  $\leq 1$  s, and
- the average force calculated over the remaining period of 4,25 s is  $\leq 150$  N.

The force is measured by means of an instrument that incorporates a rigid plate having a diameter of 80 mm and a spring having a ratio of 500 N/mm  $\pm$  50 N/mm. The spring acts on a sensing element that is connected to an amplifier having a rise and fall time not exceeding 5 ms.

For vertically moving **driven parts**, the values apply to the vertical component of the closing and opening forces and between any counter opposing edges of moving parts.

For vertically moving **driven parts**, the force is measured on the leading edge of the **driven part** when the dimension of the gap is

- 50 mm;
- 300 mm;
- 500 mm;
- 2 500 mm or 300 mm below the maximum if this is less.

For vertically moving **driven parts**, the force is measured at the following locations:

- in the centre of the leading edge;
- 200 mm from each end of the leading edge if this edge is longer than 800 mm.

For horizontally moving **driven parts**, the force is measured on the leading edge of the **driven part**, at the following heights, when the dimension of the gap is 50 mm and 500 mm:

- 50 mm;
- 300 mm from the top, for **driven parts** between 1,2 m and 2,5 m in height;
- 2 500 mm, for **driven parts** more than 2,8 m in height;
- in the centre, for **driven parts** not more than 2,8 m in height.

**DD.20.107.2.2 Drives**, intended to be used with a vertically moving **driven part** having openings in which a 50 mm diameter cylinder can be inserted, are subjected to an opening test with the **driven part** loaded with a mass of 20 kg  $\pm$  0,5 kg. The mass, having dimensions of approximately 200 mm  $\times$  200 mm  $\times$  200 mm, is fixed to the **driven part** in the most unfavourable place, with one edge adjacent to the bottom edge of the **driven part**.

The **drive** is operated to open the **driven part**. If the bottom edge of the **driven part** moves more than 500 mm, the movement of the **driven part** shall stop before the test piece comes into contact with the lintel.

**DD.20.107.2.3** *An obstacle as described in DD.20.107.1.1 except having dimensions of approximately 80 mm × 300 mm and a height of 100 mm is placed on the ground and centrally along its 300 mm length across the plane of the **driven part** opening. The **drive** is operated to close the **driven part** from opening gaps of 100 mm, 1 000 mm and the fully open position of the **driven part**. The **driven part** shall not move or only move in the opening direction. The tests with this obstacle shall be made using the non-reflective and reflective sides in turn.*

*The test is repeated from the fully open position with the obstacle positioned at 100 mm from each end of the **driven part** opening in turn.*

*A cylindrical obstacle, having a diameter of 50 mm and a length of 850 mm, is suspended by one end at a height of 900 mm above the ground and centrally in the **driven part** opening.*

*The **drive** is operated to close the **driven part** and the cylinder is swung across the **driven part** opening from an angle of 45°. The **entrapment protection system** shall cause the **driven part** to reverse its movement.*

**DD.20.108 Entrapment protection systems** shall provide an adequate level of protection in the event of a failure within the system installation wiring.

*Compliance is checked by the following test, unless the **entrapment protection system** is a **biased-off switch**.*

*The **drive** is installed with a **driven part** and supplied at **rated voltage**. The **drive** is operated to close the **driven part**. During the movement, a short circuit or open circuit is simulated in the system installation wiring.*

*Unless the **entrapment protection system** continues to operate normally, the **driven part** shall stop moving within one **cycle** of operation or the movement of the **driven part** shall only be controlled by a **biased-off switch** by the time it has completed its movement.*

*The test is repeated during the opening movement of the **driven part**.*

*If the **drive** is controlled by a programmable **electronic circuit**, the software shall contain measures to control the fault/error conditions specified in Table R.1 and is evaluated in accordance with the relevant requirements of Annex R.*

## Annex EE (normative)

### Measuring point for protective devices of horizontally moving pedestrian doors

*Dimensions in millimetres*

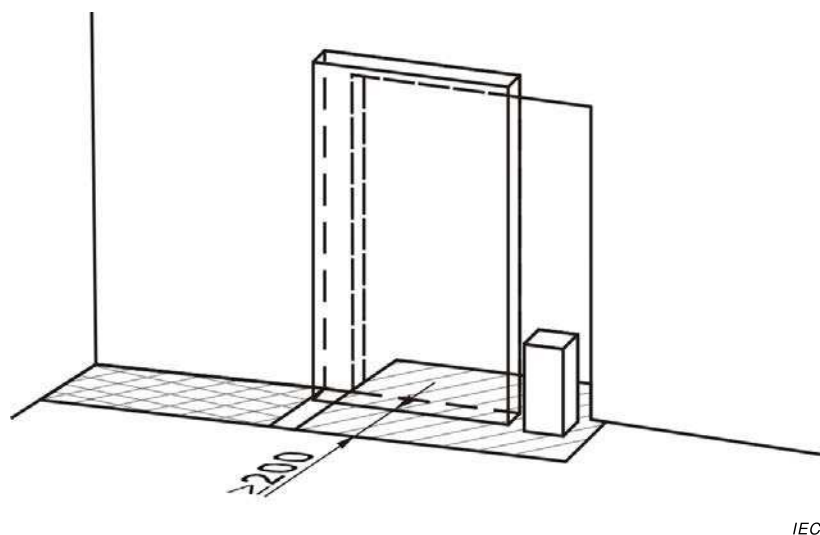

**Key**



protected area

**Figure EE.1 – Single-leaf sliding doorset**

*Dimensions in millimetres*

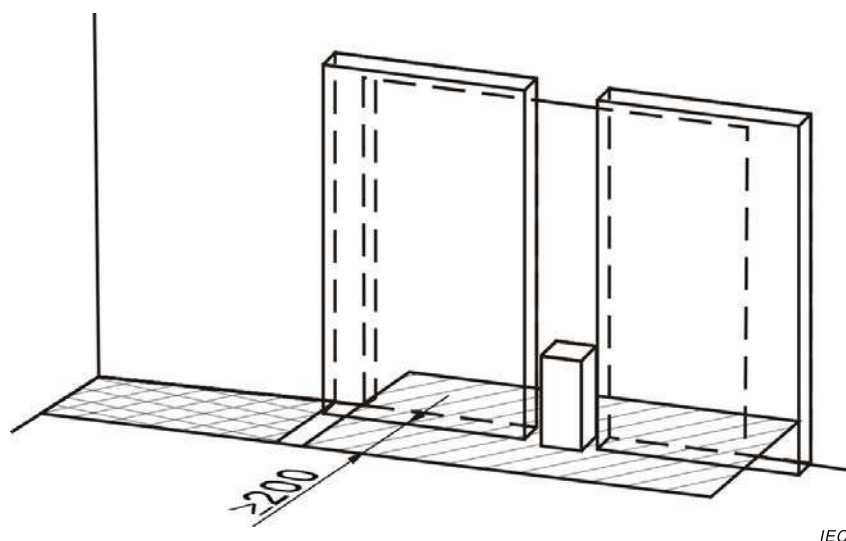

**Key**



protected area

**Figure EE.2 – Double-leaf sliding doorset**

*Dimensions in millimetres*

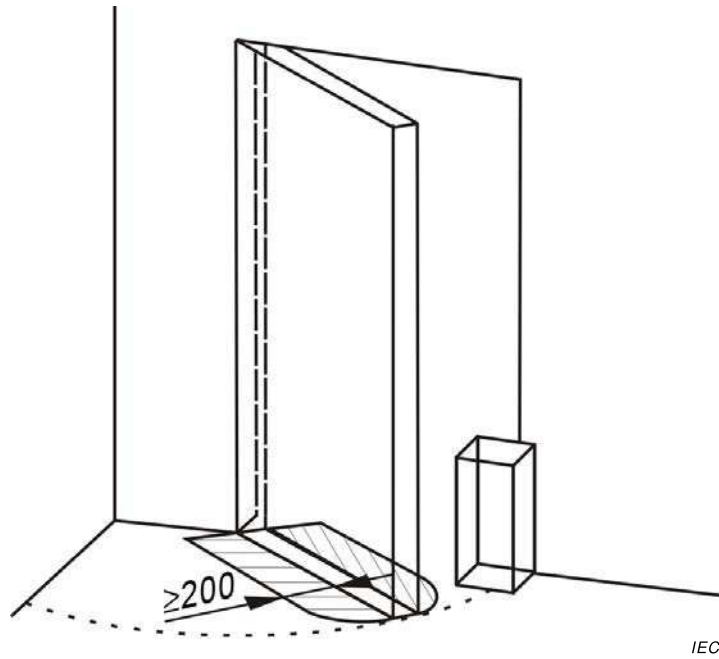

**Key**



protected area

**Figure EE.3 – Single-leaf swing doorset**

*Dimensions in millimetres*

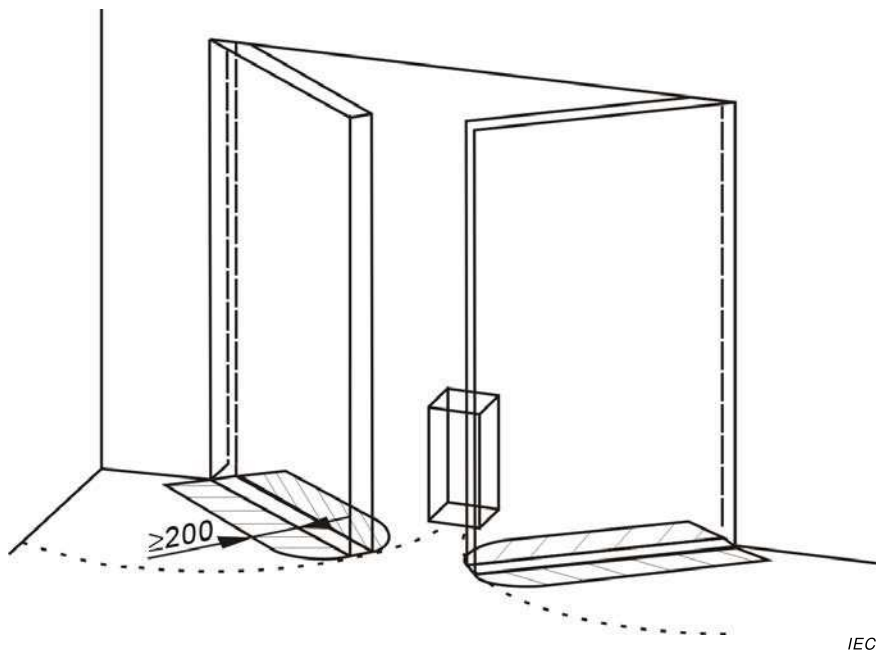

**Key**



protected area

**Figure EE.4 – Double-leaf swing doorset**

*Dimensions in millimetres*

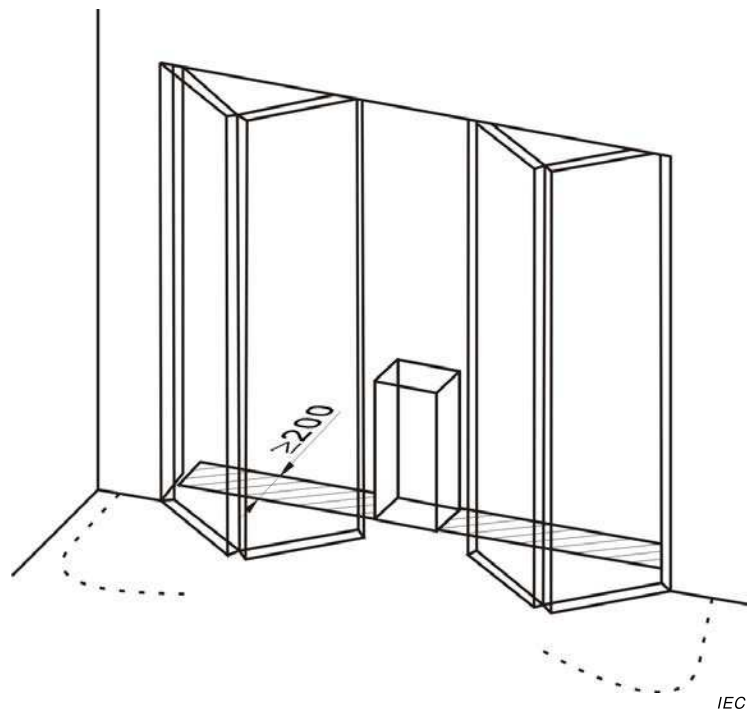

**Key**



protected area

**Figure EE.5 – Folding doorset**

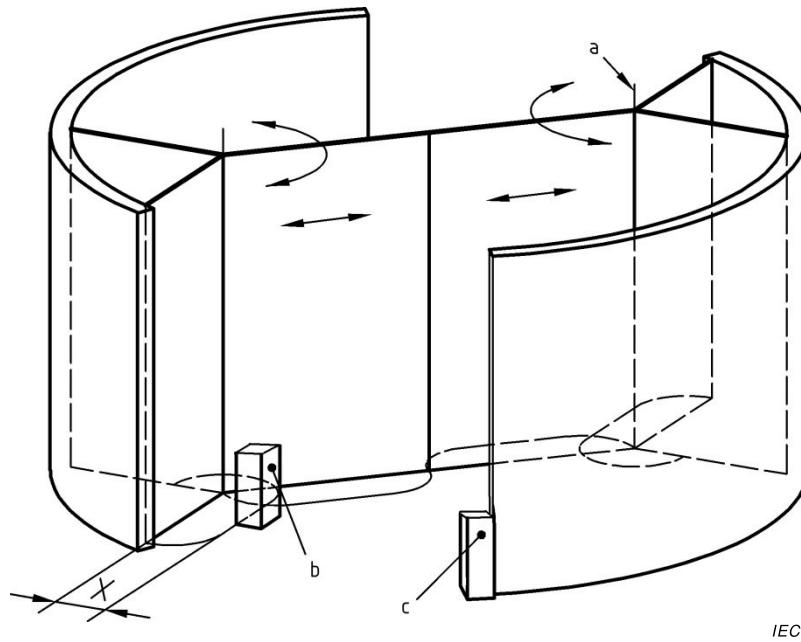

**Key**

- a pivot point for doorsets with a break-out system
- b test 1 (with CA) for doorset diameters greater than 3 000 mm
- c test 2 (with CA) for all doorset diameters, see also Clause GG.1 in Annex GG
- X protected area

**a) Reference body positions for test 1 and test 2**

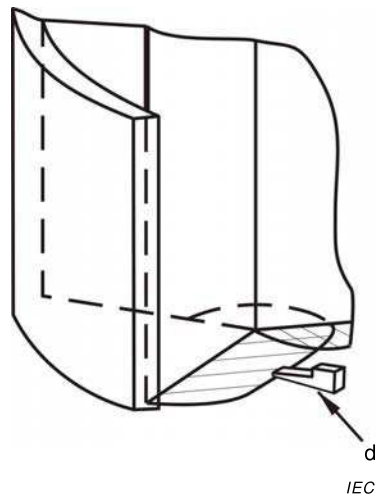

**Key**

- d test 3 (with CB) in centre of doorset leaf

**b) Reference body position for test 3**

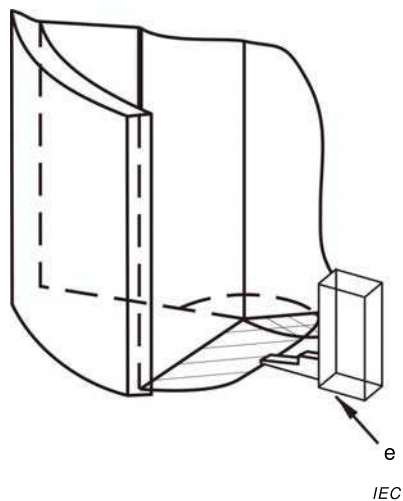

**Key**

e test 4 (with the combination of CB and CA) for all doorset diameters, in centre of doorset leaf

**c) Reference body position for test 4**

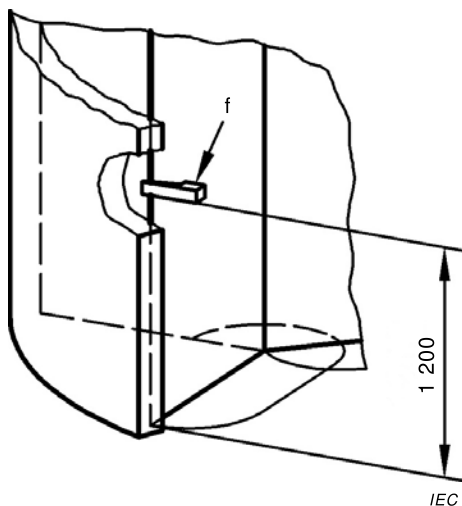

**Key**

f test 5 (with CB) for all doorset diameters

**d) Reference body position for test 5**

**Figure EE.6 – Revolving doorset, two leaves**

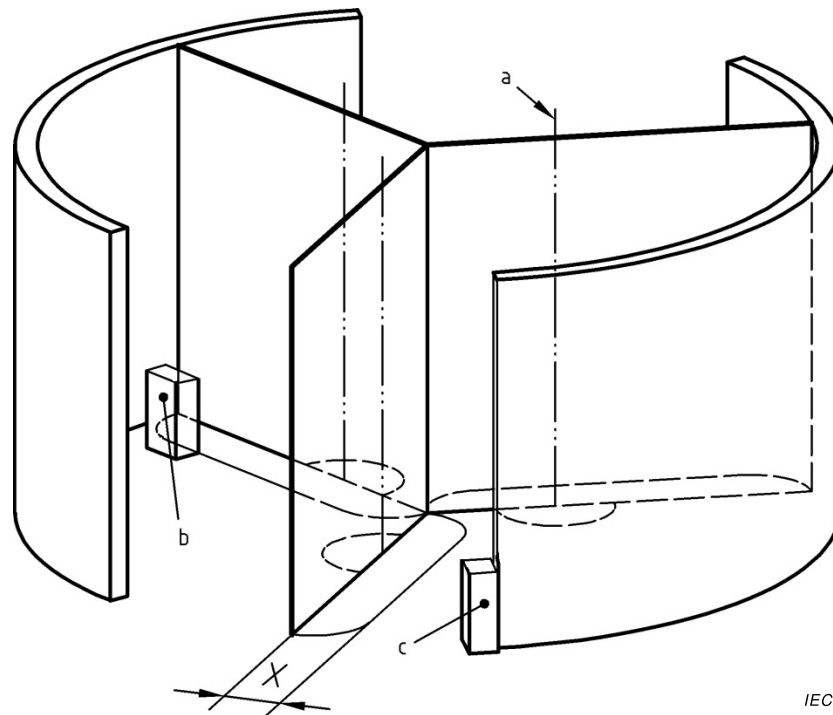

**Key**

- a pivot point for doorsets with a break-out system
- b test 1 (with CA) for doorset diameters greater than 3 000 mm, see also GG.1 in Annex GG
- c test 2 (with CA) for all doorset diameters, see also Clause GG.1 in Annex GG
- X protection area

**a) Reference body positions for test 1 and test 2**

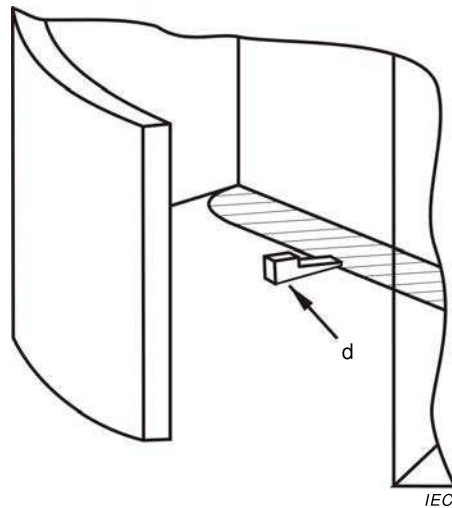

**Key**

- d test 3 (with CB) in centre of doorset leaf

**b) Reference body position for test 3**

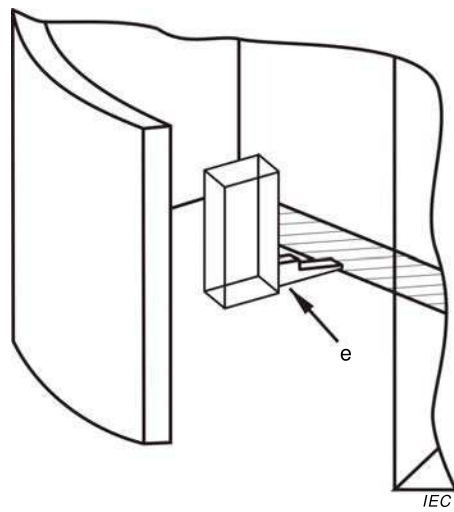

**Key**

e test 4 (with the combination of CB and CA) for all doorset diameters, in centre of doorset leaf

**c) Reference body position for test 4**

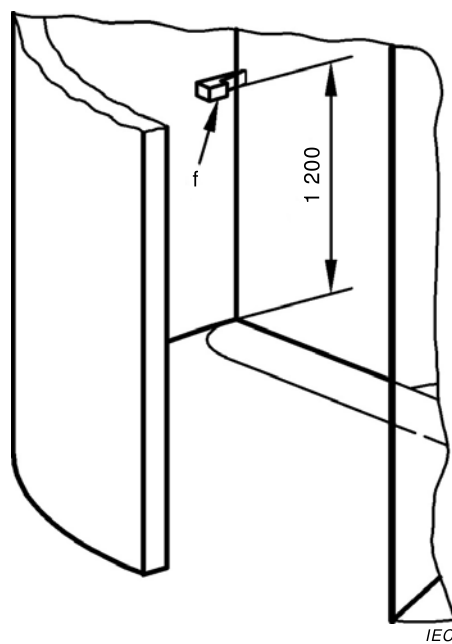

**Key**

f test 5 (with CB) for all doorset diameters

**d) Reference body position for test 5**

**Figure EE.7 – Revolving doorset, three leaves**

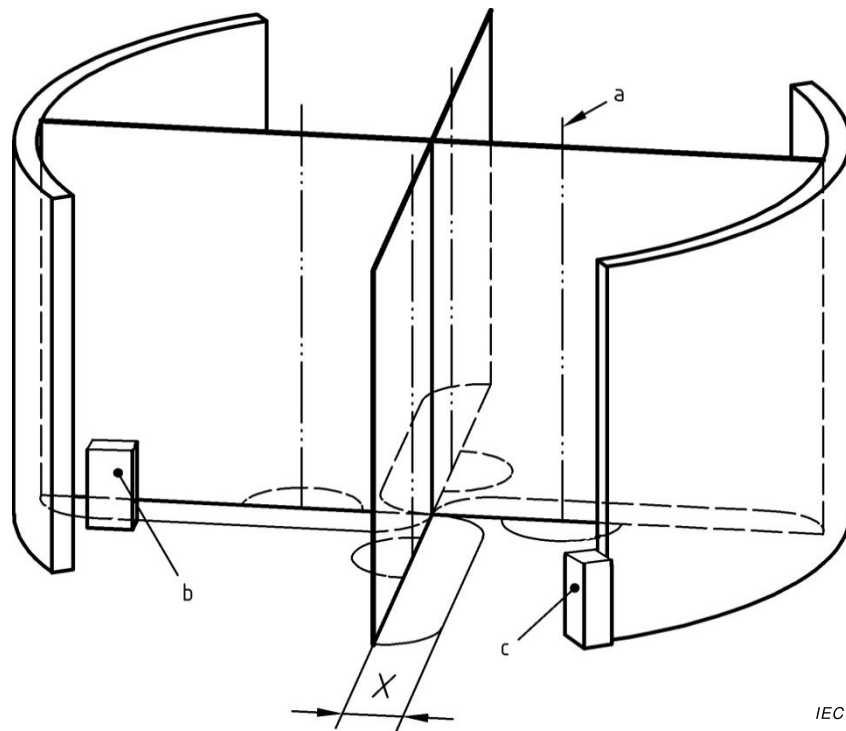

**Key**

- a pivot point for doorsets with a break-out system
- b test 1 (with CA) for doorset diameters greater than 3 000 mm
- c test 2 (with CA) for all doorset diameters, see also Clause GG.1 in Annex GG
- X protection area

**a) Reference body positions for test 1 and test 2**

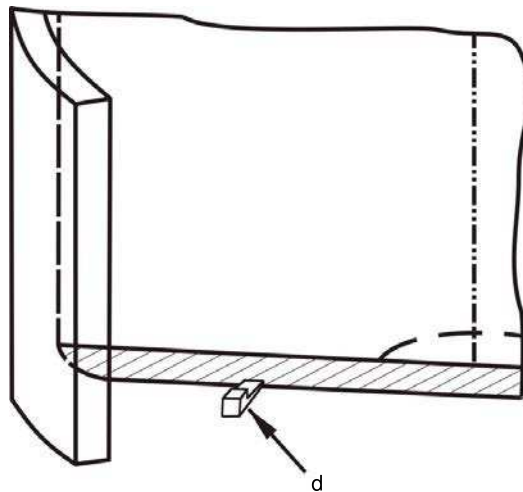

**Key**

- d test 3 (with CB) in centre of doorset leaf

**b) Reference body position for test 3**

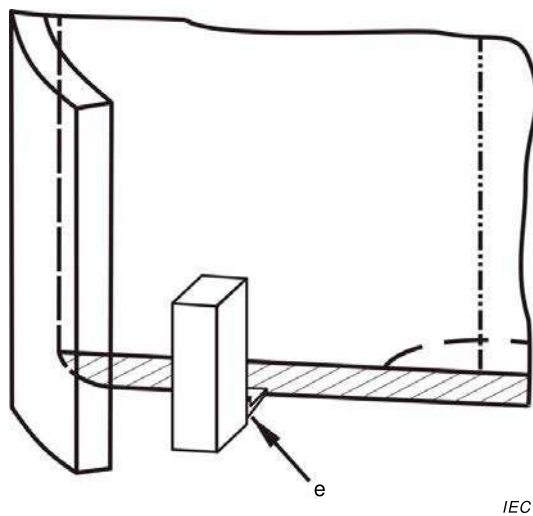

**Key**

e test 4 (with the combination of CB and CA) for all doorset diameters, in centre of doorset leaf

**c) Reference body position for test 4**

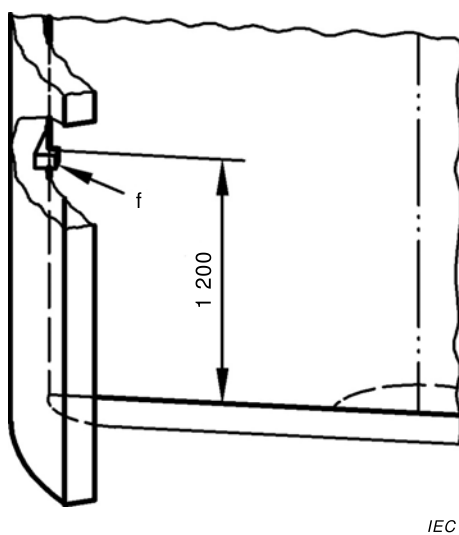

**Key**

f test 5 (with CB) for all doorset diameters

**d) Reference body position for test 5**

**Figure EE.8 – Revolving doorset, four leaves**

## Annex FF (normative)

### Reference bodies

Annex FF is applicable to **entrapment protection system** sensing devices based on active optoelectronic protective devices responsive to diffuse reflection (AOPDDRs) using a radiation wavelength in the range 820 nm to 946 nm. For sensing devices using other technologies, this annex may be used as a guide.

An **entrapment protection system** shall always be tested on a complete power operated doorset assembly.

The CA reference body (see Figure FF.1a) is a box with the dimensions 0,7 m × 0,3 m × 0,2 m. Both the top side and two sides that meet are made of a material with a diffuse reflectance value in the range of 2 % to 5 % of the wavelength of the **entrapment protection system** transmitter (e.g. IC antistatic foam; see also Figure 3 of IEC 61496-3:2008 for further materials) while the other two sides are made of a material with a diffuse reflectance value in the range of 80 % to 90 % of the wavelength of the **entrapment protection system** transmitter (e.g. white paper). The base of the reference body is not defined as it does not serve any purpose in the test.

The CB reference body (SEE Figure FF.1b) is made of a matt-black elastomer with a Shore-A hardness of  $70 \pm 5$  and a diffuse reflectance value in the range of 10 % to 90 % of the wavelength of the **entrapment protection system** transmitter.

The reference body shall be detected and the doorset shall then either stop before it touches the reference body, or reverse or switch over to low-speed motion as described in the product documentation.

**Entrapment protection systems** which do not move with the doorset leave(s) shall be tested using all relevant sides of the CA reference body.

Dimensions in millimetres

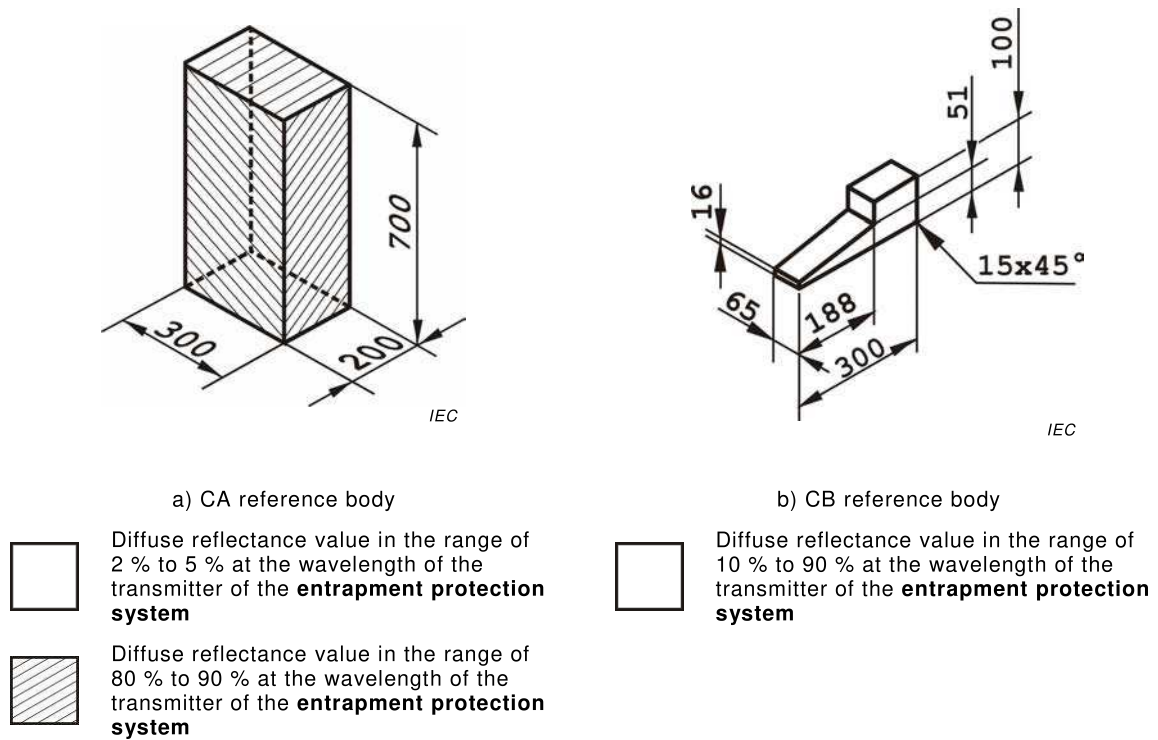

Figure FF.1 – Reference bodies

## **Annex GG** (normative)

### **Test method of entrapment protection system of drives for revolving doors**

#### **GG.1 Main closing edge/opposing closing edge – no contact protection**

If the hazard between the main closing edge and opposing closing edge is protected by an **entrapment protection system** not allowing contact with the doorset it shall be tested using a CA reference body (see Annex FF). The CA reference body shall be located next to the opposing closing edge and shall not be touched by the doorset leaf (see test 2 in Figures EE.6a, EE.7a and EE.8a).

For doorsets diameters greater than 3 000 mm the CA reference body shall additionally be located next to the edge of the doorset moving leaf and shall not be touched by the doorset leaf itself (see test 1 in Figures EE.6a, EE.7a and EE.8a)

#### **GG.2 Main closing edge/opposing closing edge – contact protection**

If the hazard between the main closing edge and opposing closing edge is protected by a device or combination of devices allowing contact with the doorset it shall be tested by a force measurement according to Annex HH at an opening width as specified in Figures II.4 or II.5 or II.6. If electro-sensitive protective equipment (ESPE) is used for speed reduction, the test shall be carried out at the speed after activation of the ESPE.

#### **GG.3 Secondary closing edge/floor**

The **entrapment protection system** protecting the hazard between the secondary closing edge and the floor shall be tested using the CB reference body.

The CB reference body is positioned on the floor so that it cannot be pushed away. The doorset shall come to a stop without completely passing over the reference body or the reference body being touched by the doorset leaf in the slanted areas. Contact with the flexible parts of the protective equipment is accepted (see test 3 in Figures EE.6c, EE.7c and EE.8c). If an **entrapment protection system** is used for speed reduction, the test shall be carried out with the combination of test bodies CB and CA (see test 4 in Figures EE.6d, EE.7d and EE.8d).

The test need not be performed if this hazard is safeguarded by safety distances.

#### **GG.4 Main closing edge/inside wall**

The **entrapment protection system** protecting the hazard between main closing edge and the inside wall shall be tested by means of the CB reference body.

The reference body is positioned at a height of 1 200 mm above the floor on the drum wall as shown in test 5 in Figures EE.6d, EE.7d and EE.8d. During the test, the reference body shall not come into contact with the doorset leaf. Contact with the flexible parts of the protective equipment is accepted.

## Annex HH (normative)

### Limitation of impact forces of pedestrian doors

#### HH.1 Permissible dynamic forces

The values of dynamic force generated by the doorset leaf when impacting a person or an obstacle shall be considered to be safe if the limits specified in Table HH.1 are not exceeded, when measured according to Annex II with an instrument complying with Clause HH.3 or HH.4.

**Table HH.1 – Permissible dynamic forces**

Doorset type	Permissible dynamic forces			Measuring points
	Between closing edges and opposing closing edges in gaps of <sup>a</sup>			
	< 200 mm	200 mm to 500 mm	> 500 mm	
Sliding doorset and sliding/swing (balanced) doorset	400 N	700 N	1 400 N	Figures II.1 and II.2
Folding doorset	400 N	700 N	1 400 N	Figures II.3
Revolving doorset	400 N	700 N	1 400 N	Figures II.4 to II.6
Flat areas are areas other than closing edges > 0,1 m <sup>2</sup> and with no side < 100 mm. The above values shall be the maximum allowed within a maximum period of time of 0,75 s ( $T_d < 0,75$ s).				
<sup>a</sup> The opposing closing edge may also be a second main closing edge or flat areas around the opening doorset.				

The leaf force measurements shall not exceed the profile shown in Figure HH.1.

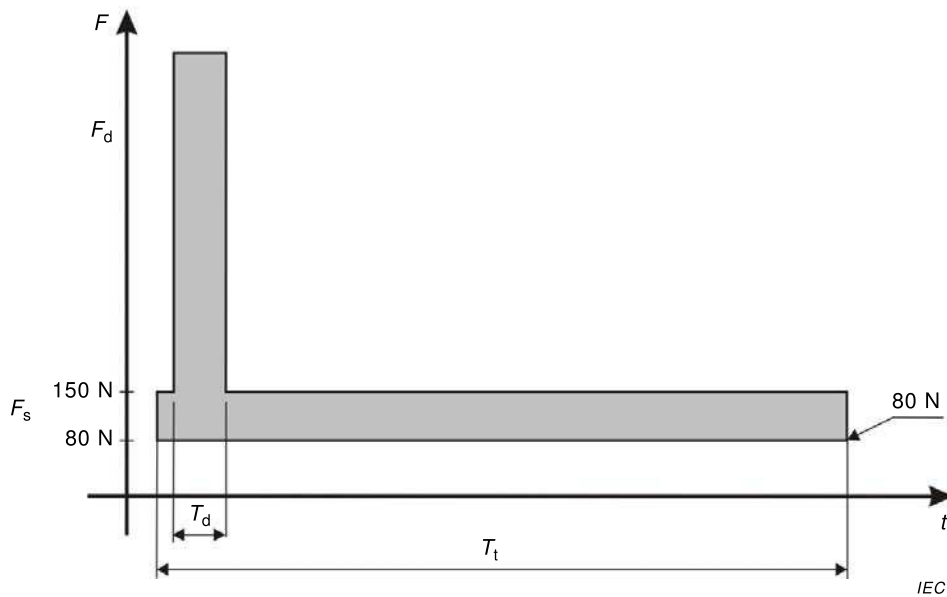

**Key**

- $F_d$  maximum force measured during the dynamic period  $T_d$  (dynamic force) – see Table 1 for permitted values
- $T_d$  period of time of max. 0,75 s starting from the first measured force exceeding 150 N
- $F_s$  maximum force measured outside the dynamic period  $T_d$  (static force)
- $T_t$  period of 5 s starting from the first measured force exceeding 80 N and including  $T_d$

**Figure HH.1 – Force versus time**

## HH.2 Permissible static forces

After  $T_d$  has elapsed, no static force  $>150$  N is allowed. This static force shall come down to  $< 80$  N after a total time  $T_t$  of maximum 5 s.

However, after  $T_d$ , peaks exceeding 150 N but lower than the admissible dynamic forces shown in Table 1 are accepted if:

- they are decreasing from one to the other; and
- the period of oscillation is  $\leq 1$  s; and
- the average force calculated over the period of  $T_t - T_d$  is  $\leq 150$  N.

## HH.3 Impact force measuring equipment

The test equipment for measuring forces shall consist of the following parts:

- a) two contact areas with a diameter of 80 mm. The contact areas shall be made of a hard material with sufficient strength, e.g. steel;
- b) spring that gives the contact area a spring ratio of  $500 \text{ N/mm} \pm 50 \text{ N/mm}$ ;
- c) load cell;
- d) time measuring device;
- e) measuring value display/measuring value output device.

The measuring equipment shall comply with the following specification:

- rising/falling time of the load cell amplifier  $< 5$  ms;

- the equipment shall be able to give measured values with an accuracy of at least  $\pm 5\%$  or  $\pm 10\text{ N}$ , whichever is the maximum deviation;
- measurements to be given in graphical form or by displaying the values.

#### **HH.4 Field impact force measuring equipment**

Field measuring equipment need not display the values and accuracy shall at least be  $\pm 10\%$  or  $\pm 20\text{ N}$  of measured values, whichever is the maximum deviation. Calibration shall be performed at least once per year.

## Annex II (normative)

### Measuring points for limitation of impact forces of pedestrian doors

Forces (see Table HH.1) shall be measured at the measuring points ( $F$ ) shown in Figures II.1 to II.6 with the instrument of Clause HH.3 or HH.4.

*Dimensions in millimetres*

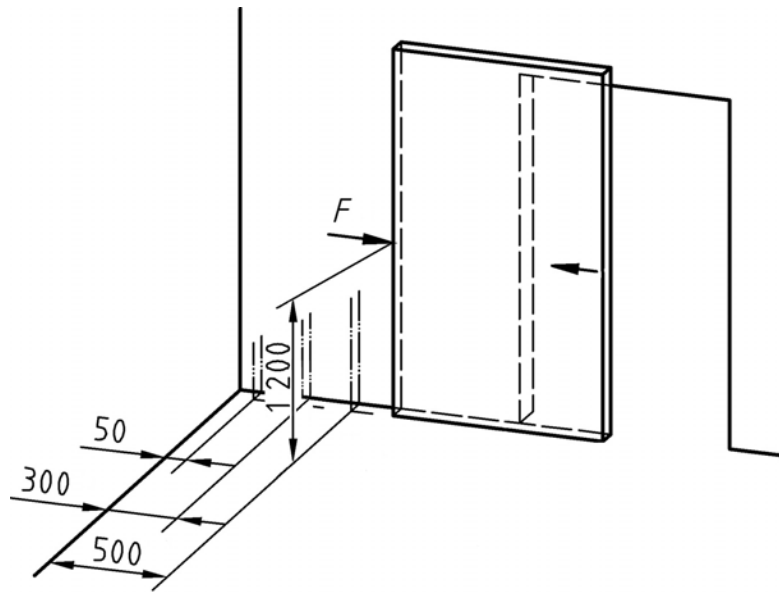

IEC

**Figure II.1 – Single-leaf sliding doorset**

*Dimensions in millimetres*

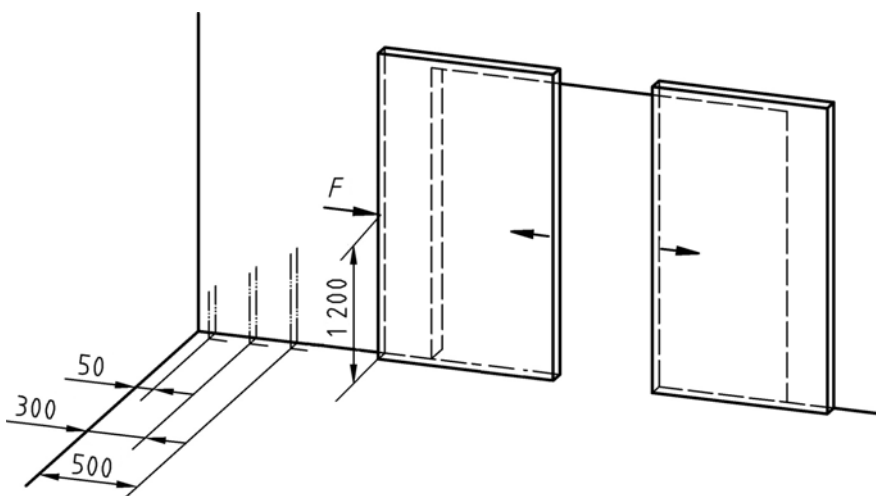

IEC

**Figure II.2 – Double-leaf sliding doorset**

*Dimensions in millimetres*



IEC

Figure II.3 – Folding doorset

Dimensions in millimetres

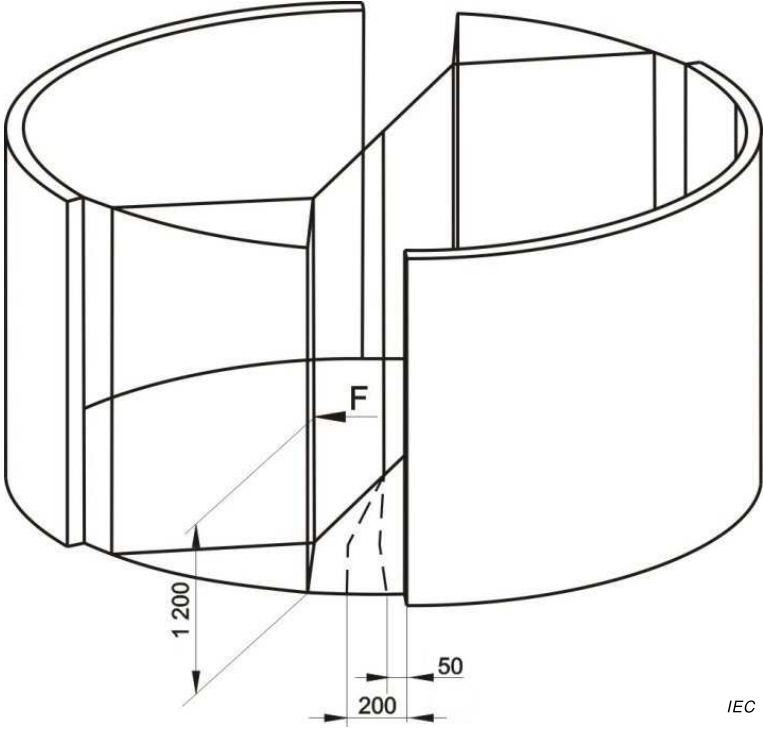

IEC

Figure II.4 – Revolving doorset, 2-leaf

Dimensions in millimetres

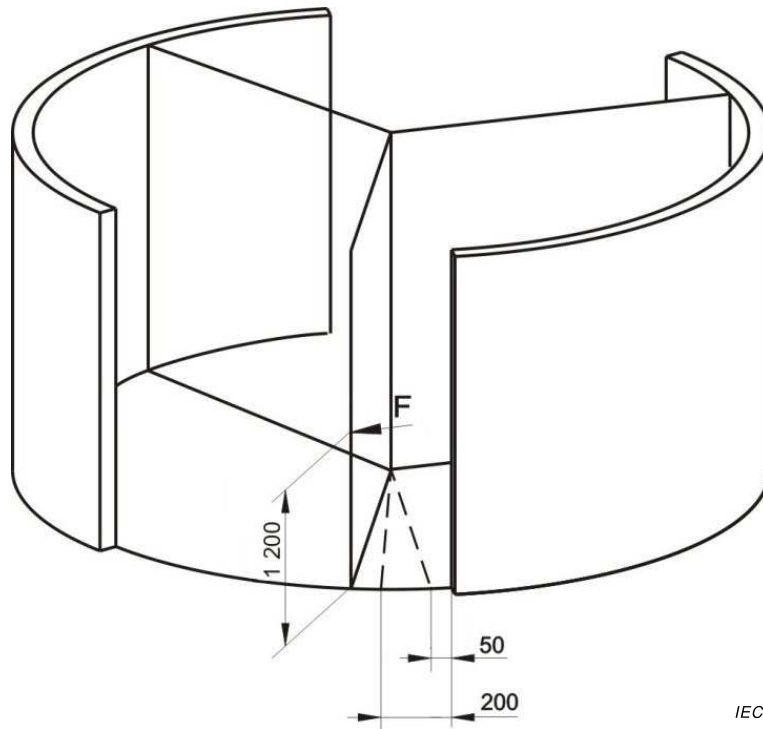

IEC

**Figure II.5 – Revolving doorset, 3-leaf**

*Dimensions in millimetres*

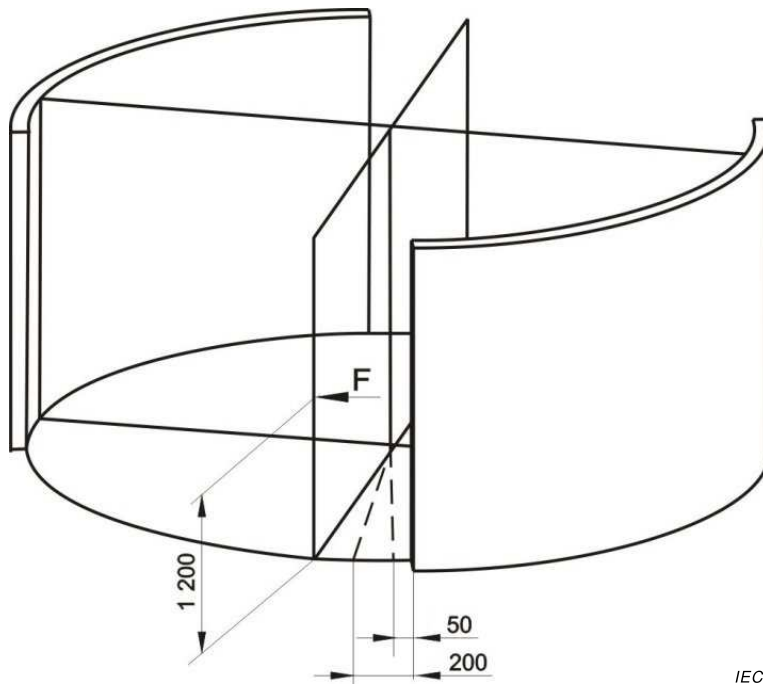

IEC

**Figure II.6 – Revolving doorset, 4-leaf**

## **Annex JJ** (normative)

### **Low energy movement of pedestrian doors**

#### **JJ.1 Low energy movement**

##### **JJ.1.1 General**

The force required to prevent a stopped doorset from opening or closing any further – measured at the main closing edge in the direction of travel – shall not exceed 67 N at any point in the opening or closing **cycle**.

The kinetic energy of a doorset in motion shall not exceed 1,69 J. Annex KK states the speed settings for various widths and masses of doorsets required to obtain results conforming to this requirement.

In the event of any interruption of mains power or failure of the **drive**, it shall be possible to open the doorset with a manual force not exceeding 67 N to release a latch and 90 N to open the doorset, when the force is applied to the main closing edge in the direction of travel.

Low energy movement of the doorset is generally not protected with additional protective devices because the kinetic energy levels are not considered to be hazardous. However, use of low energy doorset movement should only be considered when the risk assessment has taken account of elderly, frail and disabled users and indicates that the risk to these users is low.

A static closing force up to 150 N is allowed:

- when the gap between the main closing edge and the counter-closing edge is  $\leq 8$  mm for swing doorsets; or
- during the last 50 mm for any type of sliding and folding doorsets.

##### **JJ.1.2 Additional requirements for low-energy movement of hinged and swing doorsets**

###### **JJ.1.2.1 Opening time**

Doorsets shall open from closed to back check, or 80° whichever occurs first, in 3 s or longer as required in Table KK1. Back check shall not occur before 60° opening. If the doorset opens more than 90°, it shall continue at the same rate as back check speed.

NOTE Back check – Back check is the checking or slowing down of the speed of doorset opening before being fully opened (also called open check).

###### **JJ.1.2.2 Closing time**

It shall be possible to adjust the doorset on site to close from 90° to 10° in not less than 3 s and from 10° to fully closed in not less than 1,5 s as required in Table KK.1.

## Annex KK (normative)

### Speed setting for low energy movement of pedestrian doors

#### KK.1 Speed settings for low energy power operated swing doorsets

Table KK.1 shows the minimum opening time (in seconds) to back-check or to 80° open or minimum closing time (in seconds) from 90° to 10° open for most common doorset widths and masses.

**Table KK.1 – Speed settings**

Width of doorset leaf m	Mass of doorset leaf kg				
	50	60	70	80	90
	Time s				
0,75	3,0	3,0	3,0	3,0	3,2
0,85	3,0	3,0	3,2	3,4	3,6
1,00	3,2	3,4	3,7	4,0	4,2
1,20	3,8	4,1	4,5	4,8	5,0

NOTE Calculated with an energy 1,69 J and values for time rounded up to nearest one decimal place.

The minimum opening time for doorsets of other widths and/or masses shall be calculated using the following formula:

$$t = \frac{D\sqrt{m}}{2,26}$$

where

$t$  is the time, in s;

$D$  is the doorset width, in m;

$m$  is the mass of the doorset leaf, in kg;

2,26 is the conversion factor (units  $\text{mKg}^{1/2} \text{s}^{-1}$ ).

#### KK.2 Speed settings for low energy sliding doorsets

Table KK.2 shows the minimum travelling time per doorset leaf referred to the doorset mass and the travelling distance per doorset leaf.

**Table KK.2 – Minimum travelling time per doorset leaf vs. mass of door leaf**

90 % travelling distance per leaf <i>D</i>  m	Mass of doorset leaf <i>m</i> kg														
	150	140	130	120	110	100	90	80	70	60	50	40	30	20	10
	Maximum travelling speed <i>v</i> m/s														
	0,15	0,16	0,16	0,17	0,18	0,18	0,19	0,21	0,22	0,24	0,26	0,29	0,34	0,41	0,58
Minimum travelling time <i>t</i> s															
0,7	4,7	4,6	4,4	4,2	4,0	3,9	3,7	3,5	3,2	3,0	2,7	2,5	2,1	1,8	1,3
0,8	5,4	5,2	5,0	4,8	4,6	4,4	4,2	3,9	3,7	3,4	3,1	2,8	2,4	2,0	1,4
0,9	6,0	5,8	5,6	5,4	5,2	4,9	4,7	4,4	4,1	3,8	3,5	3,1	2,7	2,2	1,6
1,0	6,7	6,5	6,3	6,0	5,8	5,5	5,2	4,9	4,6	4,3	3,9	3,5	3,0	2,5	1,8
1,1	7,4	7,1	6,9	6,6	6,3	6,0	5,7	5,4	5,1	4,7	4,3	3,8	3,3	2,7	1,9
1,2	8,0	7,8	7,5	7,2	6,9	6,6	6,2	5,9	5,5	5,1	4,7	4,2	3,6	3,0	2,1
1,3	8,7	8,4	8,1	7,8	7,5	7,1	6,8	6,4	6,0	5,5	5,0	4,5	3,9	3,2	2,3
1,4	9,4	9,1	8,7	8,4	8,0	7,7	7,3	6,9	6,4	5,9	5,4	4,9	4,2	3,5	2,5
1,5	10,0	9,7	9,4	9,0	8,6	8,2	7,8	7,3	6,9	6,4	5,8	5,2	4,5	3,7	2,6

NOTE For telescopic sliding doorsets, the travelling distance applies to the fast moving leaf.

The maximum speed for doorsets of other masses shall be calculated using the kinetic energy formula, considering that the maximum admitted energy is 1,69 J:

$$E_c = \frac{1}{2} m v^2 = 1,69 \text{ (J)}$$

By knowing the leaf weight it is possible to calculate the maximum allowed speed as follows:

$$v = \sqrt{\frac{2E_c}{m}} \text{ (m/s)}$$

where

*v* is the speed, in m/s;

*E<sub>c</sub>* is the kinetic energy, in J (always 1,69 J);

*m* is the mass of the doorset leaf, in kg.

Time settings for other travelling distances per leaf and masses shall be calculated using the following formula:

$$t = \frac{D}{v}$$

where

*t* is the travelling time for opening or closing, in (s);

*D* is 90 % of the travelling distance of the leaf, in (m);

*v* is the doorset speed, in (m/s).

## Annex LL (normative)

### Safeguarding of swing pedestrian doors

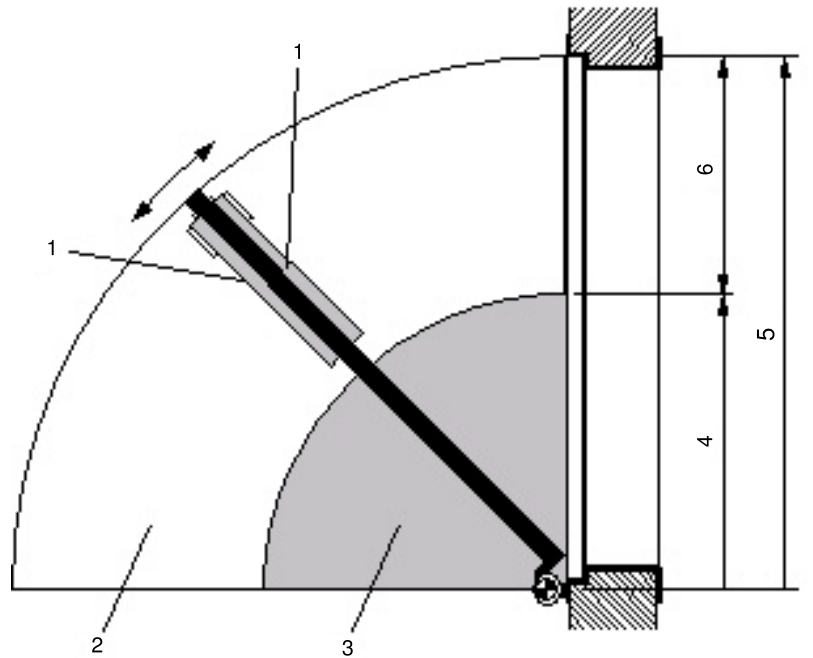

IEC

#### Key

- 1 protective device
- 2 fast area requiring protection
- 3 slow area
- 4 radius of slow area ( $r_{\text{slow area}}$ )
- 5 radius of the door ( $r_{\text{doorset}}$ )
- 6 radius of the protected area ( $d_{\text{protected}}$ )

**Figure LL.1 – Areas of the door sweep**

Figure LL.1 shows the areas of the door sweep.

Table LL.1 shows the minimum distance from the leading edge to be protected.

**Table LL.1 – Minimum width of door leaf to be protected vs. radius of doorset and doorset travelling time**

$r_{\text{doorset}}$ m	Time s										
	1	1,5	2	2,5	3	3,5	4	4,5	5	5,5	6
	$r_{\text{slow area}}$ m										
	0,16	0,24	0,32	0,4	0,48	0,56	0,64	0,72	0,8	0,88	0,95
$d_{\text{protected}}$ m											
0,7	0,54	0,46	0,38	0,30	0,22	0,14	0,06	–	–	–	–
0,8	0,64	0,56	0,48	0,40	0,32	0,24	0,16	0,08	–	–	–
0,9	0,74	0,66	0,58	0,50	0,42	0,34	0,26	0,18	0,10	0,02	–
1,0	0,84	0,76	0,68	0,60	0,52	0,44	0,36	0,28	0,20	0,12	0,05
1,1	0,94	0,86	0,78	0,70	0,62	0,54	0,46	0,38	0,30	0,22	0,15
1,2	1,04	0,96	0,88	0,80	0,72	0,64	0,56	0,48	0,40	0,32	0,25
1,3	1,14	1,06	0,98	0,90	0,82	0,74	0,66	0,58	0,50	0,42	0,35
1,4	1,24	1,16	1,08	1,00	0,92	0,84	0,76	0,68	0,60	0,52	0,45
1,5	1,34	1,26	1,18	1,10	1,02	0,94	0,86	0,78	0,70	0,62	0,55
1,6	1,44	1,36	1,28	1,20	1,12	1,04	0,96	0,88	0,80	0,72	0,65
1,7	1,54	1,46	1,38	1,30	1,22	1,14	1,06	0,98	0,90	0,82	0,75
1,8	1,64	1,56	1,48	1,40	1,32	1,24	1,16	1,08	1,00	0,92	0,85

The opening time is measured from 0° to 80° and the closing time from 90° to 10°

$r_{\text{slow area}}$  and the width of the doorset which needs to be protected ( $d_{\text{protected}}$ ) by protective devices for doorsets with other opening and closing times shall be calculated using the following formulas:

$$r_{\text{slow area}} = \frac{2}{\pi} \cdot v \cdot t = 0,16 \cdot t$$

$$d_{\text{protected}} = r_{\text{doorset}} - r_{\text{slow area}}$$

where

$t$  is the time, in s;

$r_{\text{slow area}}$  is the radius of the slow area, in m;

$v$  is the max. allowed collision speed of 0,25 m/s;

0,16 is the conversion factor, in m/s;

$d_{\text{protected}}$  is the width of the doorset which needs to be protected.

## Bibliography

The bibliography of Part 1 is applicable except as follows.

*Addition:*

IEC 60335-2-95, *Household and similar electrical appliances – Safety – Part 2-95: Particular requirements for drives for vertically moving garage doors for residential use*

IEC 60335-2-97, *Household and similar electrical appliances – Safety – Part 2-97: Particular requirements for drives for rolling shutters, awnings, blinds and similar equipment*

ISO 21927-2, *Smoke and heat control systems – Part 2: Specification for natural smoke and heat exhaust ventilators*

---

## FINAL VERSION

---

**Household and similar electrical appliances – Safety –  
Part 2-103: Particular requirements for drives for gates, doors and windows**



## CONTENTS

FOREWORD.....	5
INTRODUCTION.....	7
1 Scope.....	8
2 Normative references .....	9
3 Terms and definitions .....	9
4 General requirement.....	10
5 General conditions for the tests .....	10
6 Classification.....	11
7 Marking and instructions.....	11
8 Protection against access to live parts.....	13
9 Starting of motor-operated appliances .....	14
10 Power input and current.....	14
11 Heating.....	14
12 Void.....	14
13 Leakage current and electric strength at operating temperature.....	14
14 Transient overvoltages .....	15
15 Moisture resistance .....	15
16 Leakage current and electric strength.....	15
17 Overload protection of transformers and associated circuits .....	15
18 Endurance .....	15
19 Abnormal operation .....	15
20 Stability and mechanical hazards.....	16
21 Mechanical strength .....	16
22 Construction .....	16
23 Internal wiring.....	17
24 Components .....	17
25 Supply connection and external flexible cords .....	17
26 Terminals for external conductors.....	18
27 Provision for earthing .....	18
28 Screws and connections .....	18
29 Clearances, creepage distances and solid insulation .....	18
30 Resistance to heat and fire.....	18
31 Resistance to rusting.....	19
32 Radiation, toxicity and similar hazards.....	19
Annexes .....	22
Annex R (normative) Software evaluation .....	23
Annex AA (normative) Drives for powered pedestrian doors used in emergency routes and emergency exits.....	24
Annex DD (normative) Drives for horizontally and vertically moving doors and gates .....	37
Annex EE (normative) Measuring point for protective devices of horizontally moving pedestrian doors.....	44
Annex BB (normative) Drives for windows.....	26

Annex CC (normative) Drives for pedestrian doors.....	32
Annex FF (normative) Reference bodies .....	53
Annex GG (normative) Test method of entrapment protection system of drives for revolving doors .....	55
GG.1 Main closing edge/opposing closing edge – no contact protection .....	55
GG.2 Main closing edge/opposing closing edge – contact protection.....	55
GG.3 Secondary closing edge/floor .....	55
GG.4 Main closing edge/inside wall.....	55
Annex HH (normative) Limitation of impact forces of pedestrian doors .....	56
HH.1 Permissible dynamic forces.....	56
HH.2 Permissible static forces .....	57
HH.3 Impact force measuring equipment .....	57
HH.4 Field impact force measuring equipment .....	58
Annex II (normative) Measuring points for limitation of impact forces of pedestrian doors .....	59
Annex JJ (normative) Low energy movement of pedestrian doors .....	62
JJ.1 Low energy movement .....	62
JJ.1.1 General .....	62
JJ.1.2 Additional requirements for low-energy movement of hinged and swing doorsets .....	62
Annex KK (normative) Speed setting for low energy movement of pedestrian doors.....	63
KK.1 Speed settings for low energy power operated swing doorsets.....	63
KK.2 Speed settings for low energy sliding doorsets.....	63
Annex LL (normative) Safeguarding of swing pedestrian doors .....	65
Bibliography.....	67
Figure 101 – Examples of driven parts .....	20
Figure 102 – Inactive floor areas of pressure-sensitive pads .....	21
Figure CC.1 – Safety distances for opening movement of swing door .....	36
Figure EE.1 – Single-leaf sliding doorset .....	44
Figure EE.2 – Double-leaf sliding doorset .....	44
Figure EE.3 – Single-leaf swing doorset.....	45
Figure EE.4 – Double-leaf swing doorset .....	45
Figure EE.5 – Folding doorset.....	46
Figure EE.6 – Revolving doorset, two leaves .....	48
Figure EE.7 – Revolving doorset, three leaves.....	50
Figure EE.8 – Revolving doorset, four leaves.....	52
Figure FF.1 – Reference bodies.....	54
Figure HH.1 – Force versus time.....	57
Figure II.1 – Single-leaf sliding doorset .....	59
Figure II.2 – Double-leaf sliding doorset.....	59
Figure II.3 – Folding doorset .....	60
Figure II.4 – Revolving doorset, 2-leaf .....	60
Figure II.5 – Revolving doorset, 3-leaf .....	61
Figure II.6 – Revolving doorset, 4-leaf .....	61
Figure LL.1 – Areas of the door sweep.....	65

Table HH.1 – Permissible dynamic forces .....	56
Table KK.1 – Speed settings.....	63
Table KK.2 – Minimum travelling time per doorset leaf vs. mass of door leaf .....	64
Table LL.1 – Minimum width of door leaf to be protected vs. radius of doorset and doorset travelling time.....	66

## INTERNATIONAL ELECTROTECHNICAL COMMISSION

### HOUSEHOLD AND SIMILAR ELECTRICAL APPLIANCES – SAFETY –

#### Part 2-103: Particular requirements for drives for gates, doors and windows

#### FOREWORD

- 1) The International Electrotechnical Commission (IEC) is a worldwide organization for standardization comprising all national electrotechnical committees (IEC National Committees). The object of IEC is to promote international co-operation on all questions concerning standardization in the electrical and electronic fields. To this end and in addition to other activities, IEC publishes International Standards, Technical Specifications, Technical Reports, Publicly Available Specifications (PAS) and Guides (hereafter referred to as "IEC Publication(s)"). Their preparation is entrusted to technical committees; any IEC National Committee interested in the subject dealt with may participate in this preparatory work. International, governmental and non-governmental organizations liaising with the IEC also participate in this preparation. IEC collaborates closely with the International Organization for Standardization (ISO) in accordance with conditions determined by agreement between the two organizations.
- 2) The formal decisions or agreements of IEC on technical matters express, as nearly as possible, an international consensus of opinion on the relevant subjects since each technical committee has representation from all interested IEC National Committees.
- 3) IEC Publications have the form of recommendations for international use and are accepted by IEC National Committees in that sense. While all reasonable efforts are made to ensure that the technical content of IEC Publications is accurate, IEC cannot be held responsible for the way in which they are used or for any misinterpretation by any end user.
- 4) In order to promote international uniformity, IEC National Committees undertake to apply IEC Publications transparently to the maximum extent possible in their national and regional publications. Any divergence between any IEC Publication and the corresponding national or regional publication shall be clearly indicated in the latter.
- 5) IEC itself does not provide any attestation of conformity. Independent certification bodies provide conformity assessment services and, in some areas, access to IEC marks of conformity. IEC is not responsible for any services carried out by independent certification bodies.
- 6) All users should ensure that they have the latest edition of this publication.
- 7) No liability shall attach to IEC or its directors, employees, servants or agents including individual experts and members of its technical committees and IEC National Committees for any personal injury, property damage or other damage of any nature whatsoever, whether direct or indirect, or for costs (including legal fees) and expenses arising out of the publication, use of, or reliance upon, this IEC Publication or any other IEC Publications.
- 8) Attention is drawn to the Normative references cited in this publication. Use of the referenced publications is indispensable for the correct application of this publication.
- 9) Attention is drawn to the possibility that some of the elements of this IEC Publication may be the subject of patent rights. IEC shall not be held responsible for identifying any or all such patent rights.

#### **DISCLAIMER**

**This Consolidated version is not an official IEC Standard and has been prepared for user convenience. Only the current versions of the standard and its amendment(s) are to be considered the official documents.**

**This Consolidated version of IEC 60335-2-103 bears the edition number 3.1. It consists of the third edition (2015-04) [documents 61/4877A/FDIS and 61/4913/RVD] and its amendment 1 (2017-10) [documents 61/5296/CDV and 61/5382A/RVC]. The technical content is identical to the base edition and its amendment.**

**This Final version does not show where the technical content is modified by amendment 1. A separate Redline version with all changes highlighted is available in this publication.**

This part of International Standard IEC 60335 has been prepared by IEC technical committee 61: Safety of household and similar electrical appliances.

This third edition constitutes a technical revision.

The principal changes in this edition as compared with the second edition of IEC 60335-2-103 are as follows (minor changes are not listed):

- modification of requirements in Clause 20 by introduction of new annexes.

This publication has been drafted in accordance with the ISO/IEC Directives, Part 2.

This part 2 is to be used in conjunction with the latest edition of IEC 60335-1 and its amendments. It was established on the basis of the fifth edition (2010) of that standard.

NOTE 1 When “Part 1” is mentioned in this standard, it refers to IEC 60335-1.

This part 2 supplements or modifies the corresponding clauses in IEC 60335-1, so as to convert that publication into the IEC standard: Safety requirements for electric drives for gates, doors and windows.

When a particular subclause of Part 1 is not mentioned in this part 2, that subclause applies as far as is reasonable. When this standard states “addition”, “modification” or “replacement”, the relevant text in Part 1 is to be adapted accordingly.

NOTE 2 The following numbering system is used:

- subclauses, tables and figures that are numbered starting from 101 are additional to those in Part 1;
- unless notes are in a new subclause or involve notes in Part 1, they are numbered starting from 101, including those in a replaced clause or subclause;
- additional annexes are lettered AA, BB, etc.

NOTE 3 The following print types are used:

- requirements: in roman type;
- *test specifications: in italic type;*
- notes: in small roman type.

Words in **bold** in the text are defined in Clause 3. When a definition concerns an adjective, the adjective and the associated noun are also in bold.

A list of all parts of the IEC 60335 series, under the general title: *Household and similar electrical appliances – Safety*, can be found on the IEC website.

The committee has decided that the contents of the base publication and its amendment will remain unchanged until the stability date indicated on the IEC web site under "<http://webstore.iec.ch>" in the data related to the specific publication. At this date, the publication will be

- reconfirmed,
- withdrawn,
- replaced by a revised edition, or
- amended.

NOTE 4 The attention of National Committees is drawn to the fact that equipment manufacturers and testing organizations may need a transitional period following publication of a new, amended or revised IEC publication in which to make products in accordance with the new requirements and to equip themselves for conducting new or revised tests.

It is the recommendation of the committee that the content of this publication be adopted for implementation nationally not earlier than 12 months or later than 36 months from the date of publication.

The following differences exist in the countries indicated below.

- 6.1: Class 0 and class 01 are allowed for **drives** for indoor use having a rated voltage up to 150 V (Japan).

## INTRODUCTION

It has been assumed in the drafting of this International Standard that the execution of its provisions is entrusted to appropriately qualified and experienced persons.

This standard recognizes the internationally accepted level of protection against hazards such as electrical, mechanical, thermal, fire and radiation of appliances when operated as in normal use taking into account the manufacturer's instructions. It also covers abnormal situations that can be expected in practice and takes into account the way in which electromagnetic phenomena can affect the safe operation of appliances.

This standard takes into account the requirements of IEC 60364 as far as possible so that there is compatibility with the wiring rules when the appliance is connected to the supply mains. However, national wiring rules may differ.

If an appliance within the scope of this standard also incorporates functions that are covered by another part 2 of IEC 60335, the relevant part 2 is applied to each function separately, as far as is reasonable. If applicable, the influence of one function on the other is taken into account.

When a part 2 standard does not include additional requirements to cover hazards dealt with in Part 1, Part 1 applies.

NOTE 1 This means that the technical committees responsible for the part 2 standards have determined that it is not necessary to specify particular requirements for the appliance in question over and above the general requirements.

This standard is a product family standard dealing with the safety of appliances and takes precedence over horizontal and generic standards covering the same subject.

NOTE 2 Horizontal and generic standards covering a hazard are not applicable since they have been taken into consideration when developing the general and particular requirements for the IEC 60335 series of standards. For example, in the case of temperature requirements for surfaces on many appliances, generic standards, such as ISO 13732-1 for hot surfaces, are not applicable in addition to Part 1 or part 2 standards.

An appliance that complies with the text of this standard will not necessarily be considered to comply with the safety principles of the standard if, when examined and tested, it is found to have other features that impair the level of safety covered by these requirements.

An appliance employing materials or having forms of construction differing from those detailed in the requirements of this standard may be examined and tested according to the intent of the requirements and, if found to be substantially equivalent, may be considered to comply with the standard.

## HOUSEHOLD AND SIMILAR ELECTRICAL APPLIANCES – SAFETY –

### Part 2-103: Particular requirements for drives for gates, doors and windows

#### 1 Scope

This clause of Part 1 is replaced by the following.

This International Standard deals with the safety of electric **drives** for horizontally and vertically moving gates, doors, garage doors and **windows** for household and similar purposes, their **rated voltage** being not more than 250 V for single-phase **drives** and 600 V for other **drives**. It also covers the hazards associated with the movement of the **driven part**.

Battery-operated drives and other d.c. supplied **drives** are within the scope of this standard. Dual supply **drives**, either mains-supplied or battery-operated, are regarded as battery-operated **drives** when operated in the battery mode.

**Drives** not intended for normal household use but which nevertheless may be a source of danger to the public, such as **drives** intended to be used by laymen in shops, offices, hotels, restaurants, hospitals, in industry and on farms, are within the scope of this standard.

Requirements for **drives** for doors that may be used in emergency routes and exits are given in Annex AA.

NOTE 101 Examples of **drives** within the scope of this standard are **drives** for

- folding doors;
- revolving doors;
- rolling doors;
- roof **windows**;
- sectional overhead doors;
- swinging and sliding gates or doors.

Examples are shown in Figure 101.

NOTE 102 **Drives** may be supplied with a **driven part**.

As far as is practicable, this standard deals with the common hazards presented by **drives** that are encountered by all persons in and around the home. However, in general, it does not take into account

- persons (including children) whose
  - physical, sensory or mental capabilities; or
  - lack of experience and knowledgeprevents them from using the **drive** safely without supervision or instruction;
- children playing with the **drive**.

NOTE 103 Attention is drawn to the fact that in many countries additional requirements are specified by the national authorities responsible for the protection of labour and similar authorities.

NOTE 104 This standard does not apply to **drives**

- for vertically moving garage doors for residential use (60335-2-95);

- for shutters covering doors and **windows** (including locations where the door is set back from the shutter), awnings, blinds and similar equipment (60335-2-97);
- intended exclusively to be used by trained persons in commercial and industrial premises;
- for specific purposes, such as fire doors;
- for natural smoke exhaust ventilators not used as **windows** (ISO 21927-2);
- intended to be used in locations where special conditions prevail, such as the presence of a corrosive or explosive atmosphere (dust, vapour or gas).

NOTE 105 This standard does not apply to movement of a pedestrian door where such movement is based solely on stored energy.

## 2 Normative references

This clause of Part 1 is applicable except as follows.

*Addition:*

IEC 60068-2-52, *Environmental testing – Part 2: Tests – Test Kb: Salt mist, cyclic (sodium, chloride solution)*

IEC 60825-1:2014, *Safety of laser products – Part 1: Equipment classification and requirements*

IEC 61496-3:2008, *Safety of machinery – Electro-sensitive protective equipment – Part 3: Particular requirements for Active Opto-electronic Protective Devices responsive to Diffuse Reflection (AOPDDR)*

## 3 Terms and definitions

This clause of Part 1 is applicable except as follows.

### 3.1.9 Replacement:

#### **normal operation**

operation of the **drive** under the following conditions

**Drives** supplied without a **driven part** are operated with their **rated load**.

**Drives** supplied with a **driven part** are operated with the **driven part** installed in accordance with the instructions.

### 3.101

#### **drive**

motor and other components that control the movement of the **driven part**

Note 1 to entry: Examples of components are gears, controls, brakes, components for power transmission from the **drive** to the **driven part** and **entrapment protection systems**.

### 3.102

#### **driven part**

part of a gate, door, garage door or **window** that is intended to be moved by the **drive**

### 3.103

#### **window**

part in a building that opens and closes in order to regulate the air and light and that is not intended for passage

### **3.104**

#### **rated load**

force or torque assigned to the **drive** by the manufacturer

### **3.105**

#### **rated operating time**

duration of continuous operation assigned to the **drive** by the manufacturer

Note 1 to entry: During continuous operation, the **drive** may reverse its direction.

### **3.106**

#### **rated number of operating cycles**

number of uninterrupted **cycles** assigned to the **drive** by the manufacturer

### **3.107**

#### **cycle**

complete opening and closing movement of the **driven part**

Note 1 to entry: For revolving doors a **cycle** means the necessary rotation to allow a person to pass through it.

### **3.108**

#### **entrapment protection system**

part of the **drive** that protects against crushing

Note 1 to entry: An **entrapment protection system** may consist of one or more devices, such as pressure sensitive edges, passive infrared and active light sensing devices, **biased-off switches** or motor current monitoring devices.

Note 2 to entry: An **entrapment protection system** may be incorporated in the motor assembly or installed separately.

### **3.109**

#### **biased-off switch**

hold to run device that initiates and maintains the **drive** movement only as long as the manual control is actuated

### **3.110**

#### **automatic drive**

**drive** that operates the **driven part** in at least one direction without intentional activation by the user

### **3.111**

#### **horizontally moving pedestrian door**

swinging, sliding or rotating door designed for pedestrian use

### **3.112**

#### **reversible drive**

**drive** that can be manually operated with or without power in both directions by manual action on the **driven part**

## **4 General requirement**

This clause of Part 1 is applicable.

## **5 General conditions for the tests**

This clause of Part 1 is applicable except as follows.

### **5.2 Addition:**

When a test has to be carried out with a **driven part**, the **driven part** specified for installation with the **drive** that gives the most unfavourable conditions for the test is used. The **drive** is adjusted in accordance with the instructions.

The **driven part** may be simulated by an artificial load.

#### 5.5 Addition:

A wicket door is kept in the fully closed position if it travels together with the door during the tests or in the fully open position or completely removed position if it does not travel with the door during the tests.

#### 5.7 Addition:

If the **drive** is marked with an ambient temperature beyond the range of +5 °C to +40 °C, the tests of Clauses 11, 13, BB.20.101, BB.20.105, BB.20.106, BB.20.107, BB.20.109, CC.20.103, CC.20.104, CC.20.105, CC.20.106, DD.20.105, DD.20.106, DD.20.107, DD.20.108, and 21 are carried out at the most unfavourable marked temperature.

**5.101 Drives** shall be tested for compliance with this standard for any of the following modes of operation as intended by the manufacturer:

- automatic operation (operation in at least one direction without intentional activation by the user);
- impulse activation (operation in either direction with an intentional activation by the user);
- biased-off (hold to run) operation.

Whenever required by the instructions, components shall be added or changed to perform the tests.

## 6 Classification

This clause of Part 1 is applicable except as follows.

#### 6.1 Modification:

**Drives** shall be **class I**, **class II** or **class III**.

#### 6.2 Addition:

**Drives**, or parts of **drives**, that are intended for exposure to outdoor conditions shall be at least IPX4.

## 7 Marking and instructions

This clause of Part 1 is applicable except as follows.

#### 7.1 Addition:

**Drives** shall be marked with their ambient temperature range.

**Drives** supplied without a **driven part** shall be marked with

- the **rated load**, in newtons (N) or in newton-metres (Nm);

- the **rated operating time**, in minutes, unless the **drive** is intended for continuous operation.

**Drives** supplied with a **driven part** shall be marked with the **rated number of operating cycles** or the **cycles** per hour, unless the **drive** is intended for continuous operation.

#### 7.6 Addition:



[symbol ISO 7000-0533 (2004-01)]

upper limit of temperature



[symbol ISO 7000-0534 (2004-01)]

lower limit of temperature

#### 7.12 Addition:

The instructions shall state the substance of the following:

**WARNING:** Important safety instructions. It is important for the safety of persons to follow these instructions. Save these instructions.

The instructions shall include the substance of the following:

- do not allow children to play with fixed controls. Keep remote controls away from children;
- explanation of mode indicators;
- details on how to use any manual release, or **reversible drive** used as a manual release, and if applicable, state that activation of the manual release may cause uncontrolled movement of the driven part due to mechanical failures or an out-of-balance condition;
- when operating a biased-off switch, make sure that other persons are kept away;
- when closing a window that has been opened by a smoke control system, make sure that other persons are kept away;
- details on how to re-adjust controls, if applicable;
- frequently examine the installation for imbalance where applicable and signs of wear or damage to cables, springs and mounting. Do not use if repair or adjustment is necessary;
- disconnect the supply(s) when cleaning or other maintenance is being carried out.

#### 7.12.1 Addition:

The installation instructions shall state the substance of the following:

**WARNING:** Important safety instructions. Follow all instructions since incorrect installation can lead to severe injury.

The installation instructions shall specify the type, size and mass of the **driven part**, locations where the **drive** can be installed and shall include details of whether the **drive** is suitable only for balanced driven vertical parts.

They shall state that the installer shall check that the temperature range marked on the **drive** is suitable for the location.

They shall state that the drive

- cannot be used when the wicket door is open (for **drives** that are constructed so the **drive** can only operate when the wicket door is closed); or
- cannot be used when the wicket door is closed (for **drives** that are constructed so the **drive** can only operate when the wicket door is open or removed).

The instructions shall include the substance of the following:

- the necessary information for safe handling of a **drive** weighing more than 20 kg. This information shall describe how to use the handling means, such as hooks and ropes;
- vertical doors and gates need an anti-drop feature or device;
- before installing the drive, check that the driven part is in good mechanical condition, opens and closes properly and correctly balanced where applicable;
- information if a hazardous part of the **drive** is intended to be installed at a height of at least 2,5 m above floor level or other access level;
- except for **horizontally moving pedestrian doors**, ensure that entrapment between the driven part and the surrounding fixed parts due to the opening movement of the driven part is avoided;
- for **horizontally moving pedestrian doors**, ensure that entrapment between the driven part and the surrounding fixed parts due to the movement of the driven part is avoided. This can be achieved if the relevant distance does not exceed 8 mm. However, the following distances are considered sufficient to avoid entrapments for the parts of the body identified:
  - for fingers, a distance greater than 25 mm;
  - for feet, a distance greater than 50 mm;
  - for heads, a distance greater than 200 mm; and
  - for the whole body, a distance greater than 500 mm.

If these distances cannot be achieved, safeguarding devices shall be provided;

- details of the maximum allowed distance from the wall that is parallel to the sliding movement to the outside of horizontally sliding **driven parts**;
- details for the installation of the **drive** and its associated components, including details of relevant accessories required for alternate modes of operation;
- that the actuating member of a **biased-off switch** is to be located within direct sight of the **driven part** but away from moving parts. Unless it is key operated, it is to be installed at a minimum height of 1,5 m and not accessible to the public;
- details on how to set controls;
- after installation, ensure that the mechanism is properly adjusted and that the protection system and any manual release function correctly;
- permanently fix the label concerning the manual release, adjacent to its actuating member.

**7.101 Drives** having a manual release shall be supplied with a label describing how to use the release unless the information is already marked on the **drive**.

*Compliance is checked by inspection.*

## **8 Protection against access to live parts**

This clause of Part 1 is applicable except as follows.

## 8.2 Addition:

**Basic insulation** and parts separated from **live parts** by **basic insulation** may be touched during adjustment, if a **tool** is needed to gain access to the adjustment means.

## 9 Starting of motor-operated appliances

This clause of Part 1 is not applicable.

## 10 Power input and current

This clause of Part 1 is applicable except as follows.

### 10.1 Modification:

*Instead of determining the mean value, the maximum value of power input is determined, the effect of inrush currents being ignored.*

## 11 Heating

This clause of Part 1 is applicable except as follows.

### 11.7 Replacement:

**Drives** for continuous operation are operated for consecutive **cycles** until steady conditions are established.

**Drives** not for continuous operation are operated as follows:

**Drives** for gates for one household and horizontally moving garage doors for one household are operated without rest periods for three cycles or the **rated number of operating cycles**, whichever is longer.

**Drives** for **windows** drives are operated without rest periods for the **rated number of operating cycles**.

Other **drives** are operated without rest periods for the **rated number of operating cycles** but for not less than five **cycles** of operation.

## 12 Void

## 13 Leakage current and electric strength at operating temperature

This clause of Part 1 is applicable except as follows.

### 13.3 Addition:

*In Table 4, add the following to table footnote a:*

*The test voltage for 600 V multi-phase appliances is that specified for a **working voltage** > 250 V, where U is taken as the **rated voltage**.*

## 14 Transient overvoltages

This clause of Part 1 is applicable.

## 15 Moisture resistance

This clause of Part 1 is applicable except as follows.

### 15.1.2 Addition:

*Tubular **drives** are installed in a tube that is open at both ends and has the largest diameter specified in the instructions. The tube has a length twice that of the motor and is mounted on a support as in normal use. The support is rotated at a speed of 1 r/min.*

## 16 Leakage current and electric strength

This clause of Part 1 is applicable as follows.

### 16.3 In Table 7, add the following to table footnote a:

*The test voltage for 600 V multi-phase appliances is that specified for a **working voltage** > 250 V, where U is taken as the **rated voltage**.*

## 17 Overload protection of transformers and associated circuits

This clause of Part 1 is applicable.

## 18 Endurance

This clause of Part 1 is not applicable.

## 19 Abnormal operation

This clause of Part 1 is applicable except as follows.

### 19.1 Addition:

*Compliance is also checked by the test of 19.101.*

### 19.11.2 Addition:

*If the **drive** can be operated when any of the fault conditions are simulated, the applicable tests of BB.20.104, BB.20.107, CC.20.105, DD.20.104 and DD.20.107 are carried out, the **drive**, however, being supplied at **rated voltage**.*

*Either the **drive** continues to fulfill the requirements, or, after a maximum of one **cycle** of operation, it shall stop with the **driven part** in a safe position, or the **drive** shall change to a **biased-off switch** mode of operation.*

### 19.11.4.8 Replacement:

*The **drive** is supplied at **rated voltage** and operated under **normal operation**. After approximately 60 s, the power supply voltage is reduced to a level such that the **drive** ceases*

*to respond to user inputs or parts controlled by the programmable component cease to operate, whichever occurs first. This value of supply voltage is recorded. The **drive** is supplied at **rated voltage** and operated under **normal operation**. The voltage is then reduced to a value of approximately 10 % less than the recorded voltage. It is held at this value for approximately 60 s and then increased to **rated voltage**. The rate of decrease and increase of the power supply voltage is to be approximately 10 V/s.*

*The **drive** shall either continue to move in the same direction of movement in its operating **cycle** at which the voltage decrease occurred or a manual operation shall be required to restart it.*

**19.13 Addition:**

*During the test of 19.101, the winding temperature shall not exceed the values specified in 19.9.*

**19.101 Drives**, other than those for continuous operation, are supplied at **rated voltage** and operated continuously under **normal operation**.

## **20 Stability and mechanical hazards**

This clause of Part 1 is replaced by the following annexes.

Annex BB Drives for windows.

Annex CC Drives for pedestrian doors.

Annex DD Drives for horizontally and vertically moving doors, horizontally moving garage doors and gates.

## **21 Mechanical strength**

This clause of Part 1 is applicable.

## **22 Construction**

This clause of Part 1 is applicable except as follows.

**22.40** Not applicable.

**22.46 Addition:**

If compliance with the requirements in Clause 20 relies on the operation of a programmable **electronic circuit**, the software shall contain measures to control the fault/error conditions specified in Table R.1.

**22.101 Drives** weighing more than 20 kg shall incorporate suitable means for handling, such as hooks.

*Compliance is checked by inspection.*

**22.102** All controls supplied with the **drive** shall be marked to indicate the functions in the same way.

When the **drive** is provided with a dedicated stop button, that stop button shall be clearly identifiable.

*Compliance is checked by inspection.*

**22.103** When several modes of operation can be selected by the user, the selected mode shall be clearly indicated.

*Compliance is checked by inspection.*

**22.104** It shall only be possible to make adjustments that could affect compliance with this standard by means of a **tool** or by use of a code.

*Compliance is checked by inspection.*

**22.105** A **drive** for a door or gate incorporating a wicket door shall be constructed so that the **drive**

- cannot be operated when the wicket door is open (for **drives** that are constructed so the **drive** can only operate when the wicket door is closed); or
- cannot be operated when the wicket door is closed (for **drives** that are constructed so the **drive** can only operate when the wicket door is open or removed).

*Compliance is checked by inspection.*

**22.106** **Drives** shall be supplied with all associated components necessary for compliance with this standard for the defined mode of operation. Components required for alternative modes of operation may be delivered separately provided they are listed in the instructions.

*Compliance is checked by inspection.*

**22.107** Controls shall not be capable of overriding an **entrapment protection system** unless they can only activate the **drive** in sight of the **driven part**.

*Compliance is checked by test.*

## **23 Internal wiring**

This clause of Part 1 is applicable.

## **24 Components**

This clause of Part 1 is applicable except as follows.

### **24.1.3** *Addition:*

*If a switch is used to disconnect the **drive** when the manual release is operated, the switch is tested for 300 **cycles** of operation.*

## **25 Supply connection and external flexible cords**

This clause of Part 1 is applicable except as follows.

### **25.5** *Modification:*

**Type Z attachment** is allowed for separate power supplies for indoor use for **drives** having a **rated power input** not exceeding 100 W.

**25.7 Addition:**

The **supply cord** of **drives** for outdoor use shall be polychloroprene sheathed and not be lighter than ordinary polychloroprene sheathed flexible cord (code designation 60245 IEC 57).

## **26 Terminals for external conductors**

This clause of Part 1 is applicable.

## **27 Provision for earthing**

This clause of Part 1 is applicable.

## **28 Screws and connections**

This clause of Part 1 is applicable.

## **29 Clearances, creepage distances and solid insulation**

This clause of Part 1 is applicable except as follows.

**29.1 Addition:**

*For a **rated voltage** > 300 V and ≤ 346 V, the rated impulse voltage is for*

- *overvoltage category I: 2 500 V;*
- *overvoltage category II: 4 000 V;*
- *overvoltage category III: 6 000 V.*

**29.3.4 Addition:**

*For a **rated voltage** > 300 V and ≤ 346 V, the minimum thickness for accessible parts of **reinforced insulation** consisting of a single layer is for*

- *overvoltage category I: 0,6 mm;*
- *overvoltage category II: 1,2 mm;*
- *overvoltage category III: 2,0 mm.*

## **30 Resistance to heat and fire**

This clause of Part 1 is applicable except as follows.

**30.2 Addition:**

*For **drives** operated by a **biased-off switch**, 30.2.2 is applicable.*

*For other **drives**, 30.2.3 is applicable.*

### 31 Resistance to rusting

This clause of Part 1 is applicable except as follows.

*Addition:*

*For parts intended to be installed outdoors, compliance is checked by the salt mist test of IEC 60068-2-52, severity 2 being applicable.*

*Before the test, coatings are scratched by means of a hardened steel pin, the end of which has the form of a cone with an angle of 40°. Its tip is rounded with a radius of 0,25 mm ± 0,02 mm. The pin is loaded so that the force exerted along its axis is 10 N ± 0,5 N. The scratches are made by drawing the pin along the surfaces of the coating at a speed of approximately 20 mm/s. Five scratches are made at least 5 mm apart and at least 5 mm from the edges.*

*After the test, the **drive** shall not have deteriorated to such an extent that compliance with this standard, in particular with Clauses 8 and 27, is impaired. The coating shall not be broken and shall not have loosened from the metal surface.*

### 32 Radiation, toxicity and similar hazards

This clause of Part 1 is applicable except as follows.

**32.101 Drives** incorporating a laser shall be constructed so that they provide adequate protection from laser radiation.

*Compliance is checked by the following test.*

***Detachable parts** are removed. Any **accessible controls** are adjusted to give the highest laser radiation even if a tool is required to make the adjustment. If the control is inaccessible, it is also adjusted to give the highest laser radiation unless its actuating member is adequately locked in position.*

NOTE Solder or sealing compound is considered to provide adequate locking.

*The **drive** is supplied at **rated voltage** and operated under **normal operation**. The laser radiation is measured in accordance with 5.2 of IEC 60825-1:2014 and the accessible emission level shall not exceed the limits for a Class 1 laser product specified in Table 3 of that standard for an emission duration of 100 s.*

*The test is repeated but under the conditions specified in Clause 19 and the laser radiation measured again. The accessible emission level shall not exceed five times the limits specified for Class I for wavelengths of 400 nm to 700 nm. For other wavelengths, it shall not exceed the limits for a Class 3R laser product as specified in Table 6 of IEC 60825-1:2014.*

*If compliance with IEC 60825-1 relies on the operation of an interlock, this interlock shall be of the fail-safe type or be tested for 30 000 cycles of operation under the conditions of 24.1.4.*

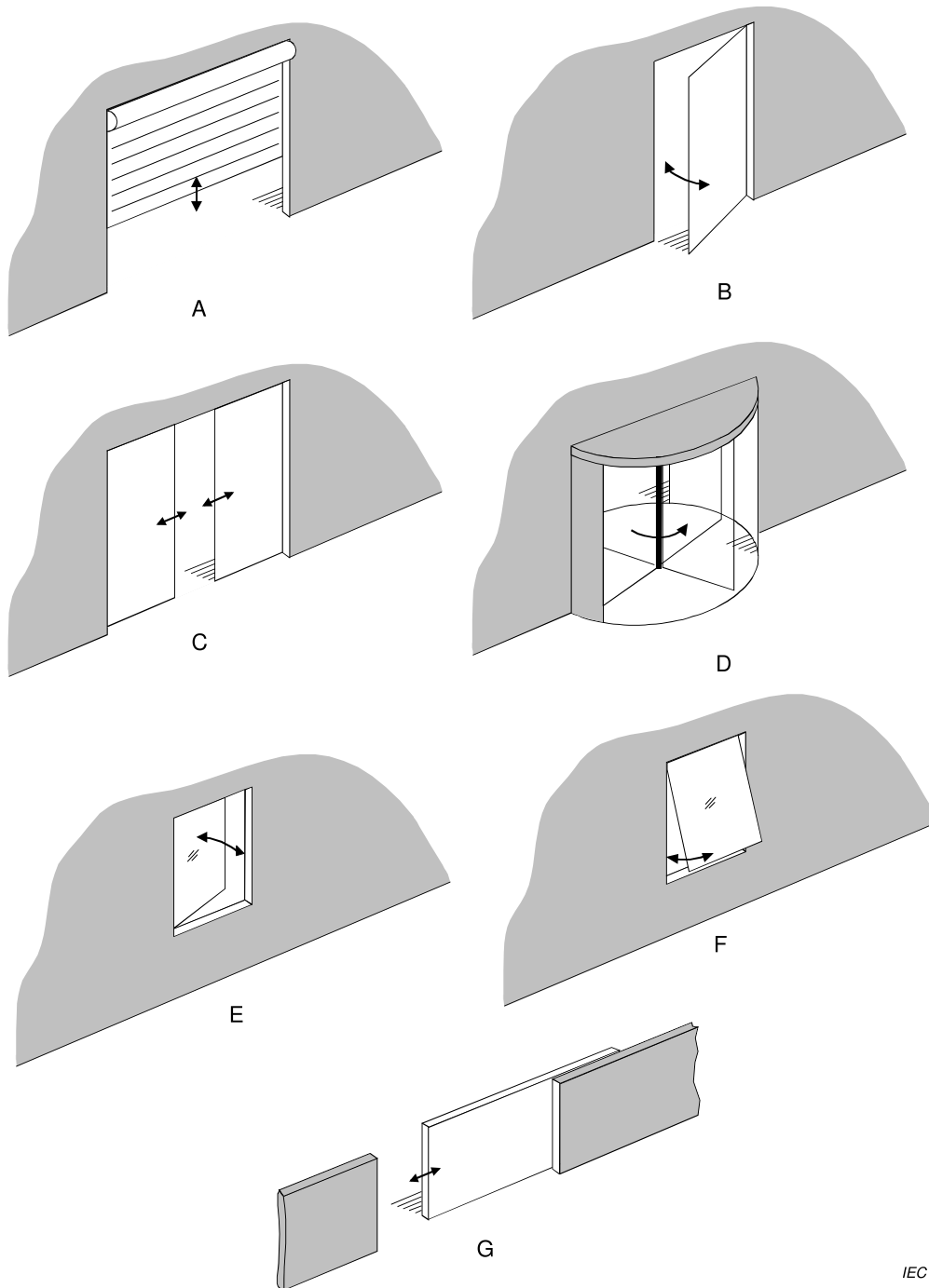

**Key**



- A rolling door
- B horizontally swinging door
- C horizontally sliding door
- D revolving door
- E vertically hinged **window** (horizontally moving)
- F horizontally hinged **window** (vertically moving)
- G horizontally sliding gate

**Figure 101 – Examples of driven parts**

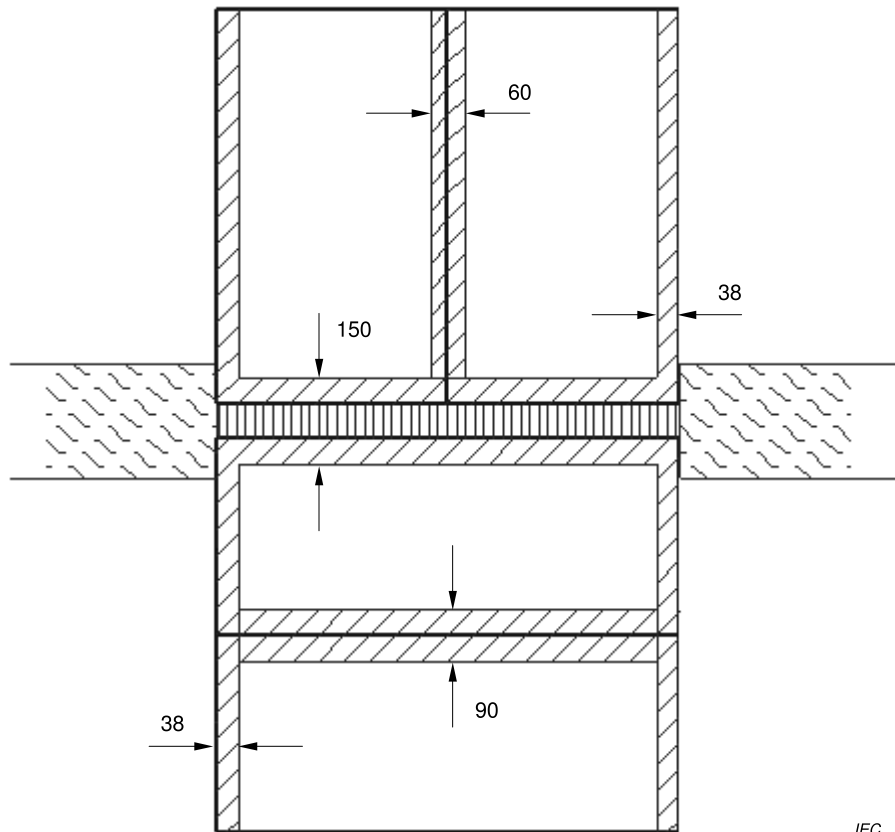
*Dimensions in millimetres*



**Key**

-  threshold
-  inactive area
-  wall

**Figure 102 – Inactive floor areas of pressure-sensitive pads**

## **Annexes**

The annexes of Part 1 are applicable except as follows.

## **Annex R** (normative)

### **Software evaluation**

This annex of Part 1 is applicable except as follows:

#### **R.2.2.5** *Addition:*

For other programmable **electronic circuits** with functions requiring software incorporating measures to control the fault/error conditions specified in Table R.1, detection of a fault/error shall occur within one cycle of operation if compliance with Clause 20 is impaired.

#### **R.2.2.9** *Addition:*

For other programmable electronic circuits, the software and safety-related hardware under its control shall be initialized and shall terminate within one cycle of operation if compliance Clause 20 is impaired.

## Annex AA (normative)

### Drives for powered pedestrian doors used in emergency routes and emergency exits

The following additions to this standard are applicable for **drives** for doors used in emergency routes and emergency exits.

NOTE In many countries, additional requirements are specified by national authorities.

#### 7 Marking and instructions

7.7 Where terminals for connection to a fire alarm system are provided, these shall be identified.

7.12 The instructions shall include the substance of the following:

Ensure that controls that can be set for a locked position are only activated when there are no other persons in the room.

7.12.1 The instructions shall include the substance of the following:

Unless the system allows break out in the escape direction, **drives** are to be connected so that doors either open in the escape direction or provide a clear escape path.

NOTE Sliding doors are considered to provide a clear escape path.

#### 20 Stability and mechanical hazards

This clause of Part 1 is replaced by the requirements and tests specified in Annex CC.

#### 22 Construction

22.108 **Drives** shall be constructed so that they cannot be put into a locked mode that prevents the door from being opened from the inside unless a night security position is selected by a key, code system or similar means.

*Compliance is checked by inspection.*

22.109 **Drives** shall be constructed so that they operate break-out doors or automatic-opening doors.

*Compliance is checked by inspection.*

22.110 **Drives** for break-out doors shall be constructed so that they release the door in the event of an emergency.

*Compliance is checked by the following test.*

*The **drive** is installed with a door and supplied at **rated voltage**. A force of 220 N is applied at a height of  $1\text{ m} \pm 10\text{ mm}$  to the leading edge of the door in the break-out direction. The door shall become released from the **drive**.*

**22.111 Drives** for automatic-opening doors shall be constructed so that the door opens automatically if the power supply fails and the system has not been deliberately selected to be in the security position.

*Compliance is checked by the test of 22.111.1, and if a battery is required, also with 22.111.2 and 22.111.3.*

**22.111.1** *The **drive** is installed with a door and supplied at **rated voltage**, any battery being fully charged. The supply is disconnected and the door shall start to open immediately at a speed of at least 200 mm/s. It shall then remain open.*

**22.111.2** *The **drive** is installed with a door and supplied at **rated voltage**, the battery being fully charged. The battery is discharged at a rate of approximately 25 % of its rated capacity per hour. The door shall start to open within 4 h, the opening speed being at least 200 mm/s. It shall then remain open.*

**22.111.3** *The **drive** is installed with a door and supplied at **rated voltage**. The battery is disconnected. The door shall start to open within 30 min, the opening speed being at least 200 mm/s. It shall then remain open.*

## Annex BB (normative)

### Drives for windows

#### 20 Stability and mechanical hazards

This clause of Part 1 is applicable except as follows.

**20.1** Not applicable

**20.2** *Addition:*

Moving parts of **drives** intended to be installed at a height of at least 2,5 m above the ground or other access level are considered to be positioned so to provide adequate protection against personal injury in normal use.

NOTE 101 Stairs and terraces are examples of access levels. Surfaces not normally used for standing on, such as window-sills, and movable equipment such as ladders, are not considered to be access levels.

**BB.20.101** **Drives** for **windows** shall operate so that the movement of the **window** is not likely to cause an injury.

*Compliance is checked as follows:*

- **drives** controlled by a **biased-off switch**, by the requirement and test of BB.20.104;
- **drives** incorporating an **entrapment protection system**, by the relevant requirement and tests of BB.20.107 and BB.20.109.

*Other **drives** are subjected to the following test.*

*The **drive** is installed with a **window** and supplied at the most unfavourable voltage between 0,94 and 1,06 times **rated voltage**. The **drive** is adjusted for the highest opening and closing forces, if the adjustment is mentioned in the instructions.*

*The **drive** is operated to open the **window**. The speed of the leading edge shall not exceed 50 mm/s.*

*When fully open, the gap between counter opposing edges shall not exceed 200 mm, unless the opening movement is controlled by a smoke control system. The **drive** is then operated to close the **window** and the speed of the leading edge shall not exceed 15 mm/s.*

*If the **drive** is controlled by a programmable **electronic circuit**, the software shall contain measures to control the fault/error conditions specified in Table R.1 and is evaluated in accordance with the relevant requirements of Annex R.*

**BB.20.102** Where a manual release or **reversible drive** is provided, it shall be easy to operate. Operation of the release shall not give rise to a hazard such as kickback or unexpected operation of the **drive**.

The **drive** shall not create any hazard when the manual release is activated.

Operation of a **reversible drive** used as a means for a manual release shall not give rise to a hazard.

*Compliance is checked by the following test.*

*Automatic operation of **automatic drives** is disabled.*

*The **drive** is installed with a **window** and supplied at the most unfavourable voltage between 0,94 and 1,06 times **rated voltage**. The **drive** is adjusted for the highest opening and closing forces, if such adjustment is mentioned in the instructions. The manual release is operated when the **window** has stopped at each terminal position, in turn. The release or **reversible drive** shall be operable with a force not exceeding 220 N or a torque not exceeding 1,6 Nm. The force is applied as stated in the instructions.*

*The test is repeated with the power supply interrupted.*

*When the manual release has been activated, the power supply is then restored and the **drive** activated. The **drive** shall not move, or if the **drive** moves, all requirements of this standard shall be met.*

**BB.20.103** A mechanical fault in the **drive** shall not result in a hazardous operation.

*Compliance is checked by inspection and, if necessary, by test.*

*The inspection shall evaluate which parts can affect the safety of operation and whether they are likely to break or become loose. These parts may be part of the **drive** or used for connecting the **drive** to the **window**.*

NOTE Examples of parts that are evaluated are screws, pins, shafts, wheels, chains and supporting parts.

*If inspection cannot determine whether the **drive** will continue to operate normally or stop its movement when the part has failed, the following test is carried out.*

*The **drive** is installed with a **window**, the force exerted by the **drive** being adjusted to its highest value in accordance with the instructions. The **drive** is supplied at the most unfavourable voltage between 0,94 and 1,06 times **rated voltage**.*

*The faults are introduced one at a time and the **drive** is operated as in normal use.*

*Unless the **drive** and the **window** continue to operate normally, all of the following conditions shall be fulfilled:*

- the **drive** shall stop operating at least by the end of the **cycle** of movement;*
- further operation shall not be possible;*
- the speed of the **window** shall not increase by more than 20 %.*

**BB.20.104 Drives** controlled by a **biased-off switch** shall stop when its actuating member is released.

*Compliance is checked by the following test.*

The **drive** is installed with a **window** and supplied at the most unfavourable voltage between 0,94 and 1,06 times **rated voltage**. It is operated to close the **window**.

When the actuating member is released, the leading edge of the **window** shall stop within a distance of 20 mm.

*The test is repeated during the opening movement of the **window**.*

*The requirement for the **window** to stop within the specified distance only applies if the closing force exerted by the **window** exceeds 150 N, as measured in BB.20.107.2.*

*If the **drive** is controlled by a programmable **electronic circuit**, the software shall contain measures to control the fault/error conditions specified in Table R.1 and is evaluated in accordance with the relevant requirements of Annex R.*

**BB.20.105** During the movement of the **drive** in either direction, the actuation of a manual control shall stop the movement if there is no separate button for the stop function.

If the **drive** has a single button for controlling the movement, further actuation shall reverse the direction of movement.

If the **drive** has three buttons for controlling the movement, one button shall be a stop button.

These requirements do not apply to controls affecting automatic modes of operation.

Any button that has a stop function shall not require a key to stop the **drive**.

*Compliance is checked by a manual test.*

NOTE The test can be carried out without a **window**.

**BB.20.106 Drives** shall not restart automatically after the movement has stopped unintentionally.

NOTE 1 Unintentional stopping may be caused by interruption of the power supply or by operation of a **thermal cut-out**.

*Compliance is checked by the following tests.*

*The **drive** is supplied at **rated voltage** and operated under **normal operation**. The supply is then interrupted. After the supply is restored, the **drive** shall not restart automatically. However, **automatic drives** may re-start, provided that they function as in normal use.*

*The **drive** is operated again and operation of the **thermal cut-out** is simulated. After the fault condition has been removed, the **drive** shall not restart automatically. However, **automatic drives** may re-start, provided that they function as in normal use.*

NOTE 2 The test can be carried out without a **window**.

*If the **drive** is controlled by a programmable **electronic circuit**, the software shall contain measures to control the fault/error conditions specified in Table R.1 and is evaluated in accordance with the relevant requirements of Annex R.*

**BB.20.107** An **entrapment protection system** in a **drive** for **windows** shall be operated to reduce the likely hood of injury to the user.

*For **drives** incorporating an **entrapment protection system** with sensing devices that prevent the **window** from coming into contact with a person, compliance is checked by the test specified in BB.20.107.1.*

*Obstacles used in the following tests shall be made of materials and colours to simulate the most unfavourable conditions. In case of doubt the obstacles shall be made of un-planed wood and painted white*

*For **drives** incorporating an **entrapment protection system** that allows the **window** to contact a person, compliance is checked by the relevant tests specified in BB.20.107.2.*

NOTE 3 In one direction of travel of the **window**, BB.20.107.1 can be met and BB.20.107.2 can be met in the opposite direction of travel.

*If the **drive** is controlled by a programmable **electronic circuit**, the software shall contain measures to control the fault/error conditions specified in Table R.1 and is evaluated in accordance with the relevant requirements of Annex R.*

**BB.20.107.1** The **drive** is installed with a **window**, the force exerted by the **drive** being adjusted to its highest value in accordance with the instructions. The **drive** is supplied at the most unfavourable voltage between 0,94 and 1,06 times **rated voltage**.

*For horizontally moving **windows**, the test of BB.20.107.1.1 is carried out.*

*For vertically moving **windows**, the test of BB.20.107.1.2 is carried out.*

**BB.20.107.1.1** *An obstacle having dimensions of approximately 25 mm × 100 mm × 300 mm, with three sides (one in each dimension) having a reflective surface, obtained by use of mirrors, fine grained stainless steel or white-gloss paint, and the other three sides being non-reflective surfaces painted dull-black, is placed at any place in the path of the leading edge and plane of the **window** and in the most unfavourable dimension. The tests with this obstacle shall be made using the non-reflective and reflective sides in turn.*

*The **drive** is operated to close the **window** from the fully open position and from a 300 mm gap. If the **window** moves, it shall stop or reverse its movement without contacting the obstacle.*

**BB.20.107.1.2** *An obstacle having dimensions of approximately 25 mm × 100 mm × 300 mm is placed at any place in the path of the leading edge along its 300 mm length across the **window** opening.*

*The **drive** is operated to close the **window** from heights of 100 mm, 1 000 mm and the fully open position of the **window**. The **window** shall not move or shall only move in the opening direction.*

**BB.20.107.2** *The **drive** is installed with a **window**. The force exerted by the **drive** is adjusted to the highest value if the force can be adjusted by the user during use or **user maintenance**. Otherwise, the force should be adjusted according to the installation instructions. The **drive** is supplied at the most unfavourable voltage between 0,94 and 1,06 times **rated voltage**.*

The **drive** is operated to close the **window** from the fully open position. The forces between the leading edge and counter opposing edges shall not exceed

- 150 N during the first 5 s after the force has exceeded 25 N;
- 25 N thereafter;

or

- 400 N during the first 0,75 s after the force has exceeded 150 N;
- 150 N during a further period of 4,25 s;
- 25 N thereafter;

However, after 0,75 s, peaks lower than 400 N are allowed, if

- they are decreasing from one to the other, and
- the period of oscillation is  $\leq 1$  s, and
- the average force calculated over the remaining period of 4,25 s is  $\leq 150$  N.

The force is measured by means of an instrument that incorporates a rigid plate having a diameter of 80 mm and a spring having a ratio of 500 N/mm  $\pm$  50 N/mm. The spring acts on a sensing element that is connected to an amplifier having a rise and fall time not exceeding 5 ms.

For vertically moving **windows**, the force is measured on the leading edge of the **windows** when the dimension of the gap is

- 50 mm;
- 300 mm;
- 500 mm.

The force is measured at the following locations:

- in the centre of the leading edge;
- 200 mm from each end of the leading edge if this edge is longer than 800 mm.

For horizontally moving **windows**, the force is measured on the leading edge of the **window**, at the following heights, when the dimension of the gap is 50 mm and 500 mm:

- 50 mm;
- 300 mm from the top, for **windows** between 1,2 m and 2,5 m in height;
- 2 500 mm, for **windows** more than 2,8 m in height;
- in the centre, for **windows** not more than 2,8 m in height.

**BB.20.108 Drives** shall prevent vertically moving **windows** from closing unexpectedly.

Compliance is checked by the following test.

The **drive** is supplied at the most unfavourable voltage between 0,94 and 1,06 times **rated voltage** but is not operated. Automatic operation of **automatic drives** is disabled. It is loaded with 1,2 times the **rated load** applied for 30 min. If the **drive** is supplied with a **window**, the load is applied to the **window** and is equal to the highest force exerted by it.

*There shall be no movement except for initial removal of any play in the system. If there is creepage in the **drive**, the **window** shall not move faster than 1 mm/s.*

NOTE 1 The highest force is determined with the **window** in the most unfavourable position, the **drive** not being energized.

NOTE 2 It is to be noted that compliance with 20.108 does not necessarily cover risks due to operation of the **window**. Anti-drop or equivalent safety devices might be necessary.

*The test is repeated with the supply disconnected.*

*If the **drive** is controlled by a programmable **electronic circuit**, the software shall contain measures to control the fault/error conditions specified in Table R.1 and is evaluated in accordance with the relevant requirements of Annex R.*

**BB.20.109 Entrapment protection systems** shall provide an adequate level of protection in the event of a failure within the system installation wiring.

*The **drive** is installed with a **window** and supplied at **rated voltage**. The **drive** is operated to close the **window**. During the movement, a short circuit or open circuit is simulated in the system installation wiring.*

*Unless the system continues to operate normally, the **window** shall stop moving within one **cycle** of operation or the movement of the **window** shall only be controlled by a **biased-off switch** by the time it has completed its movement.*

## Annex CC (normative)

### Drives for pedestrian doors

#### 20 Stability and mechanical hazards

This clause of Part 1 is applicable except as follows.

**20.1** Not applicable.

**20.2** *Addition:*

Moving parts of **drives** intended to be installed at a height of at least 2,5 m above the ground or other access level are considered to be positioned so to provide adequate protection against personal injury in normal use.

NOTE 101 Stairs and terraces are examples of access levels. Surfaces not normally used for standing on, such as window-sills, and movable equipment such as ladders, are not considered to be access levels.

For **horizontally moving pedestrian doors**, moving parts including interconnecting parts of their **drives** need not be guarded if the gap between fixed and moving parts is below 8 mm, or above 25 mm, or it is at least 2 m above the ground. This also applies to the gap between parts that may move at different speeds.

**CC.20.101** Where manual release or **reversible drive** is provided it shall be easy to operate. Operation of the release shall not give rise to a hazard such as kickback or unexpected operation of the **drive**.

The **drive** shall not create any hazard when the manual release is activated.

Operation of a **reversible drive** used as a means for a manual release shall not give rise to a hazard.

*Compliance is checked by the following test.*

*Automatic operation of **automatic drives** is disabled.*

*The **drive** is installed with a pedestrian door and supplied at the most unfavourable voltage between 0,94 and 1,06 times **rated voltage**. The **drive** is adjusted for the highest opening and closing forces, if such adjustment is mentioned in the instructions. The manual release is operated when the pedestrian door has stopped at each terminal position, in turn. The release or **reversible drive** shall be operable with a force not exceeding 220 N or a torque not exceeding 1,6 Nm. The force is applied as stated in the instructions.*

*The test is repeated with the power supply disconnected.*

*When the manual release has been activated, the power supply is then restored and the **drive** activated. The **drive** shall not move, or if the **drive** moves, all requirements of this standard shall be met.*

**CC.20.102** A mechanical fault in the **drive** shall not result in a hazardous operation.

*Compliance is checked by inspection and, if necessary, by test.*

*The inspection shall evaluate which parts can affect the safety of operation and whether they are likely to break or become loose. These parts may be part of the **drive** or used for connecting the **drive** to the pedestrian door.*

NOTE Examples of parts that are evaluated are screws, pins, shafts, wheels, chains and supporting parts.

*If inspection cannot determine whether the **drive** will continue to operate normally or stop its movement when the part has failed, the following test is carried out.*

*The **drive** is installed with a pedestrian door, the force exerted by the **drive** being adjusted to its highest value in accordance with the instructions. The **drive** is supplied at the most unfavourable voltage between 0,94 and 1,06 times **rated voltage**.*

*The faults are introduced one at a time and the **drive** is operated as in normal use.*

*Unless the **drive** and the pedestrian door continue to operate normally, all of the following conditions shall be fulfilled:*

- the **drive** shall stop operating at least by the end of the **cycle** of movement;*
- further operation shall not be possible;*
- the speed of the pedestrian door shall not increase by more than 20 %.*

**CC.20.103** During the movement of the **drive** in either direction, the actuation of a manual control shall stop the movement if there is no separate button for the stop function.

If the **drive** has a single button for controlling the movement, further actuation shall reverse the direction of movement.

If the **drive** has three buttons for controlling the movement, one button shall be a stop button.

These requirements do not apply to controls affecting automatic modes of operation.

Any button that has a stop function shall not require a key to stop the **drive**.

*Compliance is checked by a manual test.*

**CC.20.104 Drives** shall not restart automatically after the movement has stopped unintentionally.

NOTE 1 Unintentional stopping can be caused by interruption of the power supply or by operation of a **thermal cut-out**.

*Compliance is checked by the following tests.*

*The **drive** is supplied at **rated voltage** and operated under **normal operation**. The supply is then interrupted. After the supply is restored, the **drive** shall not restart automatically. However, **automatic drives** may re-start, provided that they function as in normal use.*

*The **drive** is operated again and operation of the **thermal cut-out** is simulated. After the fault condition has been removed, the **drive** shall not restart automatically. However, **automatic drives** may re-start, provided that they function as in normal use.*

NOTE 2 The test can be carried out without a pedestrian door.

*If the **drive** is controlled by a programmable **electronic circuit**, the software shall contain measures to control the fault/error conditions specified in Table R.1 and is evaluated in accordance with the relevant requirements of Annex R.*

**CC.20.105 Drives** shall incorporate an **entrapment protection system** that reduces the risk of injury when the pedestrian door moves or shall be adjustable to control the energy of the movement of the pedestrian door.

NOTE In one direction of travel of the pedestrian door, CC.20.105.1 can be met and CC.20.105.2 can be met in the opposite direction of travel.

For **drives**, incorporating an **entrapment protection system** that allows the pedestrian door to contact a person, compliance is checked by the relevant tests specified in CC.20.105.2.

If the **drive** is controlled by a programmable **electronic circuit**, the software shall contain measures to control the fault/error conditions specified in Table R.1 and is evaluated in accordance with the relevant requirements of Annex R.

**CC.20.105.1** For **drives** incorporating an **entrapment protection system** with sensing devices that prevent the pedestrian door from coming into contact with a person, compliance is checked by the following relevant tests.

The **drive** is installed with a pedestrian door, the force exerted by the **drive** being adjusted to its highest value in accordance with the instructions. The **drive** is supplied at the most unfavourable voltage between 0,94 and 1,06 times **rated voltage**.

If the sensing devices are other than pressure sensitive pads, the test specified in CC.20.105.1.1 is applied.

If the sensing devices are pressure sensitive pads, the test specified in CC.20.105.1.2 is applied.

For pedestrian doors, an **entrapment protection system** with sensing devices that continuously adapt to environmental changes shall detect a stationary obstacle for at least 30 s.

**CC.20.105.1.1** The reference bodies for the tests shall be in accordance with Annex FF.

For **horizontally moving pedestrian doors**, the **drive** is operated to open or close the **door**. For **drives** for **horizontally moving pedestrian doors** other than revolving doors, tests are carried out using the reference body positioned in the moving plane of the pedestrian door as shown in Figures EE.1 to EE.5 of Annex EE.

The reference body CA is detected in all positions of the travel area of the doorset leaves.

For **drives** for revolving doors, tests are carried out in accordance with Annex GG using the reference body positioned as shown in Figures EE.6 to EE.8 of Annex EE.

**CC.20.105.1.2** If the **entrapment protection system** incorporates a pressure-sensitive floor pad, a mass of 15 kg  $\pm$  0,5 kg having a diameter of approximately 60 mm is used.

The following inactive floor pad areas are excluded from this requirement:

- the last 38 mm on each side of the pedestrian door opening width;
- 60 mm along the junction of floor pads joined together side-by-side with the longest dimension perpendicular to the pedestrian door opening;
- 90 mm along the junction of floor pads joined together side-by-side with the longest dimension parallel to the pedestrian door opening;
- 150 mm across the junction of floor pads meeting at the threshold.

NOTE The inactive floor areas of pressure sensitive pads are shown in Figure 102.

**CC.20.105.2 Entrapment protection systems** that allow the pedestrian door to contact a person shall only be used to reduce the risk of injury for:

- the opening movement of a sliding door with the leave(s) moving along a plain part and the distance between the front surface of the leave and the fixed side screen or wall is more than 100 mm and less or equal to 150 mm;
- the opening and closing movement of a balanced door;
- the opening movement of a folding door;
- the closing movement of a folding door only in combination with an **entrapment protection system** with sensing devices that prevent the pedestrian door from coming into contact with a person installed at the outer side of the door;
- the movement of revolving doors in combination with the peripheral speed which shall not exceed 1 000 mm/s for a door with a diameter up to 3 000 mm and shall not exceed 750 mm/s for a door with a diameter over 3 000 mm.

For **drives** incorporating an **entrapment protection system** that allows the pedestrian door to contact a person, compliance is checked by the following relevant tests.

The **drive** is installed with a pedestrian door. The force exerted by the **drive** is adjusted to the highest value if the force can be adjusted by the user during use or **user maintenance**. Otherwise, the force is adjusted according to the installation instructions. The **drive** is supplied at the most unfavourable voltage between 0,94 and 1,06 times **rated voltage**.

The **drive** is operated to close and open the pedestrian door from the fully open and fully closed positions. The forces between the leading edge and counter opposing edges shall not exceed the values stated in Annex HH when measured at points (F) according to Annex II.

The force is measured by means of an instrument that incorporates a rigid plate having a diameter of 80 mm and a spring having a ratio of 500 N/mm  $\pm$  50 N/mm. The spring acts on a sensing element that is connected to an amplifier having a rise and fall time not exceeding 5 ms.

**CC.20.105.3 Drives** adjustable to control the energy of the movement of a pedestrian door, shall be in compliance with Annex JJ or Annex LL.

**Drives** adjustable to control the energy of the movement of a pedestrian door shall only be used to reduce the risk of injury for:

- the opening and closing movement of a sliding door when the movement is in accordance with Annex JJ;
- the opening and closing movement of a swing door when the movement is in accordance with Annex JJ;
- the opening and closing movement of a revolving door when the movement is in accordance with Annex JJ;
- the opening movement of a swing door when the movement is in accordance with Annex LL and sufficient safety distances are provided (see Figure CC.1);
- the closing movement of a swing door when the movement is in accordance with Annex LL.

**CC.20.106 Entrapment protection systems** shall provide an adequate level of protection in the event of a failure within the system installation wiring.

Compliance is checked by the following test.

The **drive** is installed with a pedestrian door and supplied at **rated voltage**. The **drive** is operated to close the pedestrian door. During the movement, a short circuit or open circuit is simulated in the system installation wiring.

Unless the system continues to operate normally, the pedestrian door shall stop moving within one **cycle** of operation or the movement of the pedestrian door shall only be controlled by a **biased-off switch** by the time it has completed its movement.

The test is repeated during the opening movement of the pedestrian door.

If the **drive** is controlled by a programmable **electronic circuit**, the software shall contain measures to control the fault/error conditions specified in Table R.1 and is evaluated in accordance with the relevant requirements of Annex R.

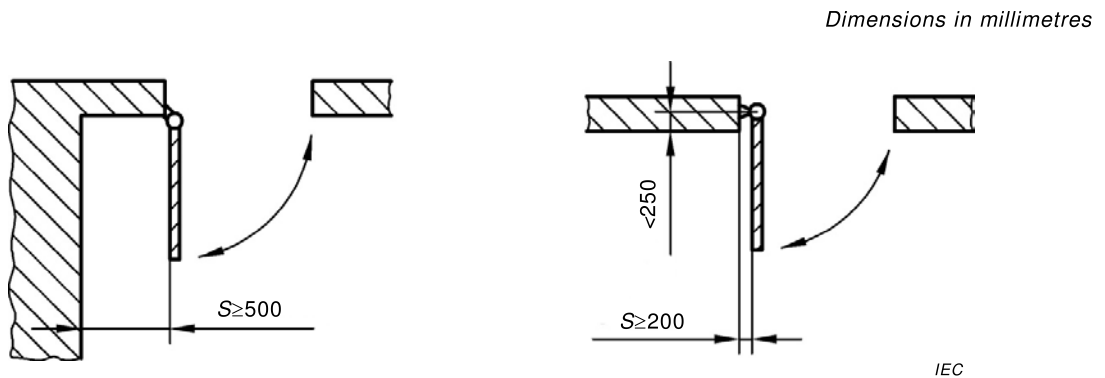

**Key**

S safety distance

**Figure CC.1 – Safety distances for opening movement of swing door**

## Annex DD (normative)

### Drives for horizontally and vertically moving doors and gates

NOTE Pedestrian doors are covered in Annex CC.

#### 20 Stability and mechanical hazards

This clause of Part 1 is applicable except as follows.

**20.1** Not applicable.

**20.2** *Addition:*

Moving parts of **drives** intended to be installed at a height of at least 2,5 m above the ground or other access level are considered to be positioned so to provide adequate protection against personal injury in normal use.

NOTE 101 Stairs and terraces are examples of access levels. Surfaces not normally used for standing on, such as window-sills, and movable equipment such as ladders, are not considered to be access levels.

**DD.20.101** **Drives** shall prevent vertically moving **driven parts** from closing unexpectedly.

*Compliance is checked by the following test.*

*The **drive** is supplied at the most unfavourable voltage between 0,94 and 1,06 times **rated voltage** but is not operated. Automatic operation of **automatic drives** is disabled. It is loaded with 1,2 times the **rated load** applied for 30 min. If the **drive** is supplied with a **driven part**, the load is applied to the **driven part** and is equal to the highest force exerted by it.*

*There shall be no movement except for initial removal of any play in the system.*

NOTE 1 The highest force is determined with the **driven part** in the most unfavourable position, the **drive** not being energized.

*The test is repeated with the supply disconnected.*

*If the **drive** is controlled by a programmable **electronic circuit**, the software shall contain measures to control the fault/error conditions specified in Table R.1 and is evaluated in accordance with the relevant requirements of Annex R.*

**DD.20.102** Where a manual release or **reversible drive** is provided, it shall be easy to operate. Operation of the release shall not give rise to a hazard such as kickback or unexpected operation of the **drive**.

The **drive** shall not create any hazard when the manual release is activated.

Operation of a **reversible drive** used as a means for a manual release shall not give rise to a hazard.

*Compliance is checked by the following test.*

*Automatic operation of **automatic drives** is disabled.*

The **drive** is installed with a **driven part** and supplied at the most unfavourable voltage between 0,94 and 1,06 times **rated voltage**. The **drive** is adjusted for the highest opening and closing forces, if such adjustment is mentioned in the instructions. The manual release is operated when the **driven part** has stopped at each terminal position, in turn. The release or **reversible drive** shall be operable with a force not exceeding 220 N or a torque not exceeding 1,6 Nm. The force is applied as stated in the instructions.

The test is repeated with the power supply interrupted.

When the manual release has been activated, the power supply is then restored and the **drive** activated. The **drive** shall not move, or if the **drive** moves, all requirements of this standard shall be met.

**DD.20.103** A mechanical fault in the **drive** shall not result in a hazardous operation.

Compliance is checked by inspection and, if necessary, by test.

**Drives** for balanced vertically **driven parts** are not tested.

NOTE 1 Balanced vertically **driven parts** can utilise springs, counterweights or other means to support the mass of the **driven part**.

The inspection shall evaluate which parts can affect the safety of operation and whether they are likely to break or become loose. These parts may be part of the **drive** or used for connecting the **drive** to the **driven part**.

NOTE 2 Examples of parts that are evaluated are screws, pins, shafts, wheels, chains and supporting parts.

If inspection cannot determine whether the **drive** will continue to operate normally or stop its movement when the part has failed, the following test is carried out.

The **drive** is installed with a **driven part**, the force exerted by the **drive** being adjusted to its highest value in accordance with the instructions. The **drive** is supplied at the most unfavourable voltage between 0,94 and 1,06 times **rated voltage**.

The faults are introduced one at a time and the **drive** is operated as in normal use.

Unless the **drive** and the **driven part** continue to operate normally, all of the following conditions shall be fulfilled:

- the **drive** shall stop operating at least by the end of the **cycle** of movement;
- further operation shall not be possible;
- the speed of the **driven part** shall not increase by more than 20 % or it shall stop within 300 mm.

NOTE 3 For vertically moving doors, anti-drop or equivalent safety devices might be necessary.

**DD.20.104** **Drives** controlled by a **biased-off switch** shall stop when the actuating member is released.

Compliance is checked by the following test.

The **drive** is installed with a **driven part** and supplied at the most unfavourable voltage between 0,94 and 1,06 times **rated voltage**. It is operated to close the **driven part**.

When the actuating member is released, the leading edge of the **driven part** shall stop within a distance of

- for door or gate other than swing type, 50 mm when the opening gap does not exceed 500 mm except for horizontally swinging **driven parts** which shall stop within 100 mm;
- for swing type door or gate, 100 mm when the opening gap does not exceed 500 mm;
- for any type of door or gate, 100 mm when the opening gap exceeds 500 mm. The test is repeated during the opening movement of the **driven part**.

The requirement for the **driven part** to stop within the specified distance only applies if the closing force exerted by the **driven part** exceeds 150 N, as measured in DD.20.107.2.1.

If the **drive** is controlled by a programmable **electronic circuit**, the software shall contain measures to control the fault/error conditions specified in Table R.1 and is evaluated in accordance with the relevant requirements of Annex R.

**DD.20.105** During the movement of the **drive** in either direction, the actuation of a manual control shall stop the movement if there is no separate button for the stop function.

If the **drive** has a single button for controlling the movement, further actuation shall reverse the direction of movement.

If the **drive** has three buttons for controlling the movement, one button shall be a stop button.

These requirements do not apply to controls operating **automatic drives**.

Any button that has a stop function shall not require a key to stop the **drive**.

*Compliance is checked by a manual test.*

NOTE The test can be carried out without a **driven part**.

If the **drive** is controlled by a programmable **electronic circuit**, the software shall contain measures to control the fault/error conditions specified in Table R.1 and is evaluated in accordance with the relevant requirements of Annex R.

**DD.20.106 Drives** shall not restart automatically after the movement has stopped unintentionally.

NOTE 1 Unintentional stopping may be caused by interruption of the power supply or by operation of a **thermal cut-out**.

*Compliance is checked by the following tests.*

The **drive** is supplied at **rated voltage** and operated under **normal operation**. The supply is then interrupted. After the supply is restored, the **drive** shall not restart automatically. However, **automatic drives** may re-start, provided that they function as in normal use.

The **drive** is operated again and operation of the **thermal cut-out** is simulated. After the fault condition has been removed, the **drive** shall not restart automatically. However, **automatic drives** may re-start, provided that they function as in normal use.

NOTE 2 The test can be carried out without a **driven part**.

**DD.20.107 Drives** not controlled by a **biased off switch** shall incorporate an **entrapment protection system** that reduces the risk of injury when the **driven part** moves.

*If the **drive** is controlled by a programmable **electronic circuit**, the software shall contain measures to control the fault/error conditions specified in Table R.1 and is evaluated in accordance with the relevant requirements of Annex R.*

*For **drives** incorporating an **entrapment protection system** with sensing devices that prevent the **driven part** from coming into contact with a person, compliance is checked by the relevant tests specified in DD.20.107.1.*

*For **drives** incorporating an **entrapment protection system** that allows the **driven part** to contact a person, compliance is checked by the tests specified in 20.107.2.*

*For **drives** incorporating an **entrapment protection system** with a non-contact sensing device that moves with the leading edge of a **driven part**, compliance is checked by the tests specified in DD.20.107.2.*

NOTE In one direction of travel of the **driven part**, DD.20.107.1 can be met and DD.20.107.2 can be met in the opposite direction of travel.

**DD.20.107.1** *The **drive** is installed with a **driven part**, the force exerted by the **drive** being adjusted to its highest value in accordance with the instructions. The **drive** is supplied at the most unfavourable voltage between 0,94 and 1,06 times **rated voltage**.*

*If the sensing devices are other than pressure sensitive pads, the tests specified in DD.20.107.1.1 to DD.20.107.1.3 are applied.*

*If the sensing devices are pressure sensitive pads, the test specified in DD.20.107.1.4 is applied.*

**DD.20.107.1.1** *An obstacle having dimensions of approximately 200 mm × 300 mm × 700 mm with three sides (one in each dimension) having a reflective surface, obtained by use of mirrors, fine grained stainless steel or white-gloss paint, and the other three sides being non reflective surfaces painted dull-black, is placed on the ground at any place in the path of the leading edges and planes of the **driven part** and in the most unfavourable position. The tests with this obstacle shall be made using the non-reflective and reflective sides in turn.*

NOTE The leading edge is the edge of the **driven part** in the direction of travel, either opening or closing.

*For horizontally moving **driven parts**, the **drive** is operated to open or close the **driven part**. If the **driven part** moves, it shall stop or reverse its movement without contacting the obstacle.*

*The obstacle is then located with the 700 mm dimension positioned vertically and raised off the ground in the worst position between the ground and 300 mm below the **driven part** height or 2 500 mm, whichever is lower.*

*The **drive** is operated to close the **driven part**. If the **driven part** moves, it shall stop or reverse its movement without contacting the obstacle.*

**DD.20.107.1.2** *For vertically moving **driven parts**, the obstacle used in DD.20.107.1.1 is placed on the ground at any place in the path of the leading edge along its 300 mm length across the **driven part** opening.*

For vertically moving **driven parts**, the **drive** is operated to close the **driven part** from heights of 100 mm, 1 000 mm and the fully open position of the **driven part**. The **driven part** shall not move or shall only move in the opening direction.

**DD.20.107.1.3** For horizontally and vertically moving **driven parts**, the obstacle used in DD.20.107.1.1 is located with the 700 mm dimension positioned vertically and is moved at a speed of  $3 \text{ m/s} \pm 0,6 \text{ m/s}$ .

For both horizontally and vertically moving **driven parts**, the obstacle is moved in a straight line through the plane of the **driven part** opening at the most unfavourable angle.

The **drive** is operated to close the **driven part**. The **driven part** shall stop or reverse its movement without contacting the obstacle.

**DD.20.107.1.4** If the **entrapment protection system** incorporates a pressure-sensitive floor pad, a mass of  $15 \text{ kg} \pm 0,5 \text{ kg}$  having a diameter of approximately 60 mm is used instead of the wooden obstacle.

The mass is placed in the path of the **driven part** and the **drive** is operated, the **driven part** shall stop or reverse its movement before contacting the mass.

The following inactive floor pad areas are excluded from this requirement:

- the last 38 mm on each side of the **driven part** opening width;
- 60 mm along the junction of floor pads joined together side-by-side with the longest dimension perpendicular to the **driven part** opening;
- 90 mm along the junction of floor pads joined together side-by-side with the longest dimension parallel to the **driven part** opening;
- 150 mm across the junction of floor pads meeting at the threshold.

NOTE 1 The inactive floor areas of pressure sensitive pads are shown in Figure 102.

**DD.20.107.2** The **drive** is installed with a **driven part**. The force exerted by the **drive** is adjusted to the highest value if the force can be adjusted by the user during use or **user maintenance**. Otherwise, the force is adjusted according to the installation instructions. The **drive** is supplied at the most unfavourable voltage between 0,94 and 1,06 times **rated voltage**.

The test of DD.20.107.2.1 is applied and

- if the **drive** is intended to be used with vertically moving **driven parts** having openings in which a 50 mm tube can be inserted, the test of DD.20.107.2.2 is applied for an opening movement;
- if the **drive** is an **automatic drive**, or a **drive** that operates the **driven part** in at least one direction by a command that can be initiated via a connection to a telecommunication or communication network, the test of DD.20.107.2.3 is applied.

**DD.20.107.2.1** The **drive** is operated to close and open the **driven part** from the fully open and fully closed positions. The forces between the leading edge and counter opposing edges shall not exceed

- 150 N during the first 5 s after the force has exceeded 25 N;
- 25 N thereafter;

or

- 400 N during the first 0,75 s after the force has exceeded 150 N;
- 150 N during a further period of 4,25 s;

- 25 N thereafter;

or for vertically moving **driven parts** used as a door;

- 600 N during the first 2 s after the force has exceeded 150 N for **driven parts** that do not swing outward and meet DD.20.107.2.3;
- 400 N during the first 2 s after the force has exceeded 150 N for **driven parts** that swing outward;
- 150 N during a further period of 3 s;
- 25 N thereafter.

However, after 0,75 s, peaks lower than 400 N are allowed, if

- they are decreasing from one to the other, and
- the period of oscillation is  $\leq 1$  s, and
- the average force calculated over the remaining period of 4,25 s is  $\leq 150$  N.

The force is measured by means of an instrument that incorporates a rigid plate having a diameter of 80 mm and a spring having a ratio of 500 N/mm  $\pm$  50 N/mm. The spring acts on a sensing element that is connected to an amplifier having a rise and fall time not exceeding 5 ms.

For vertically moving **driven parts**, the values apply to the vertical component of the closing and opening forces and between any counter opposing edges of moving parts.

For vertically moving **driven parts**, the force is measured on the leading edge of the **driven part** when the dimension of the gap is

- 50 mm;
- 300 mm;
- 500 mm;
- 2 500 mm or 300 mm below the maximum if this is less.

For vertically moving **driven parts**, the force is measured at the following locations:

- in the centre of the leading edge;
- 200 mm from each end of the leading edge if this edge is longer than 800 mm.

For horizontally moving **driven parts**, the force is measured on the leading edge of the **driven part**, at the following heights, when the dimension of the gap is 50 mm and 500 mm:

- 50 mm;
- 300 mm from the top, for **driven parts** between 1,2 m and 2,5 m in height;
- 2 500 mm, for **driven parts** more than 2,8 m in height;
- in the centre, for **driven parts** not more than 2,8 m in height.

**DD.20.107.2.2 Drives**, intended to be used with a vertically moving **driven part** having openings in which a 50 mm diameter cylinder can be inserted, are subjected to an opening test with the **driven part** loaded with a mass of 20 kg  $\pm$  0,5 kg. The mass, having dimensions of approximately 200 mm  $\times$  200 mm  $\times$  200 mm, is fixed to the **driven part** in the most unfavourable place, with one edge adjacent to the bottom edge of the **driven part**.

The **drive** is operated to open the **driven part**. If the bottom edge of the **driven part** moves more than 500 mm, the movement of the **driven part** shall stop before the test piece comes into contact with the lintel.

**DD.20.107.2.3** *An obstacle as described in DD.20.107.1.1 except having dimensions of approximately 80 mm × 300 mm and a height of 100 mm is placed on the ground and centrally along its 300 mm length across the plane of the **driven part** opening. The **drive** is operated to close the **driven part** from opening gaps of 100 mm, 1 000 mm and the fully open position of the **driven part**. The **driven part** shall not move or only move in the opening direction. The tests with this obstacle shall be made using the non-reflective and reflective sides in turn.*

*The test is repeated from the fully open position with the obstacle positioned at 100 mm from each end of the **driven part** opening in turn.*

*A cylindrical obstacle, having a diameter of 50 mm and a length of 850 mm, is suspended by one end at a height of 900 mm above the ground and centrally in the **driven part** opening.*

*The **drive** is operated to close the **driven part** and the cylinder is swung across the **driven part** opening from an angle of 45°. The **entrapment protection system** shall cause the **driven part** to reverse its movement.*

**DD.20.108 Entrapment protection systems** shall provide an adequate level of protection in the event of a failure within the system installation wiring.

*Compliance is checked by the following test, unless the **entrapment protection system** is a **biased-off switch**.*

*The **drive** is installed with a **driven part** and supplied at **rated voltage**. The **drive** is operated to close the **driven part**. During the movement, a short circuit or open circuit is simulated in the system installation wiring.*

*Unless the **entrapment protection system** continues to operate normally, the **driven part** shall stop moving within one **cycle** of operation or the movement of the **driven part** shall only be controlled by a **biased-off switch** by the time it has completed its movement.*

*The test is repeated during the opening movement of the **driven part**.*

*If the **drive** is controlled by a programmable **electronic circuit**, the software shall contain measures to control the fault/error conditions specified in Table R.1 and is evaluated in accordance with the relevant requirements of Annex R.*

**Annex EE**  
(normative)

**Measuring point for protective devices of  
horizontally moving pedestrian doors**

*Dimensions in millimetres*

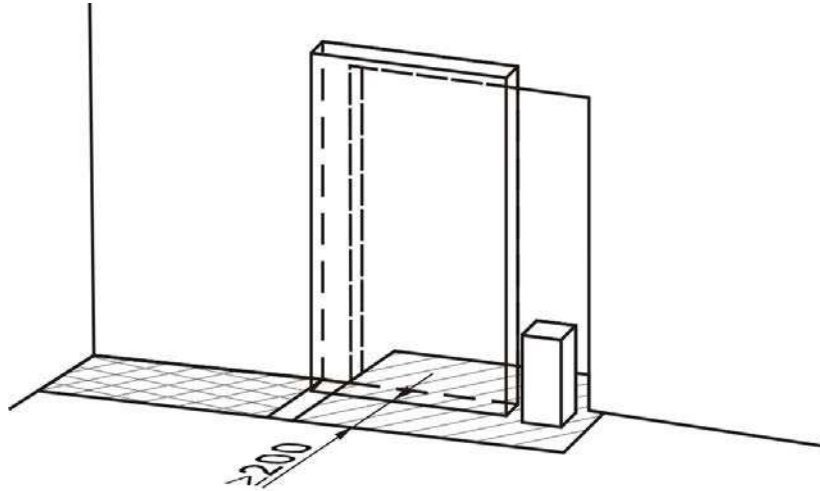

IEC

**Key**



protected area

**Figure EE.1 – Single-leaf sliding doorset**

*Dimensions in millimetres*

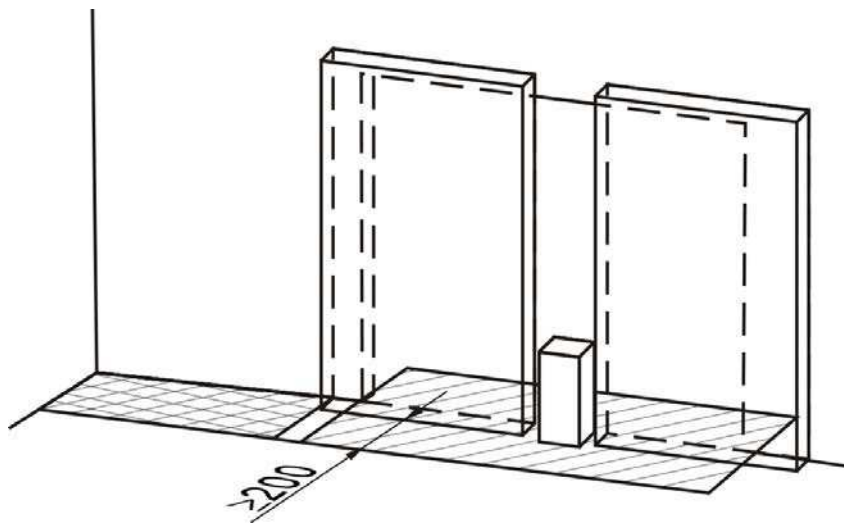

IEC

**Key**



protected area

**Figure EE.2 – Double-leaf sliding doorset**

*Dimensions in millimetres*

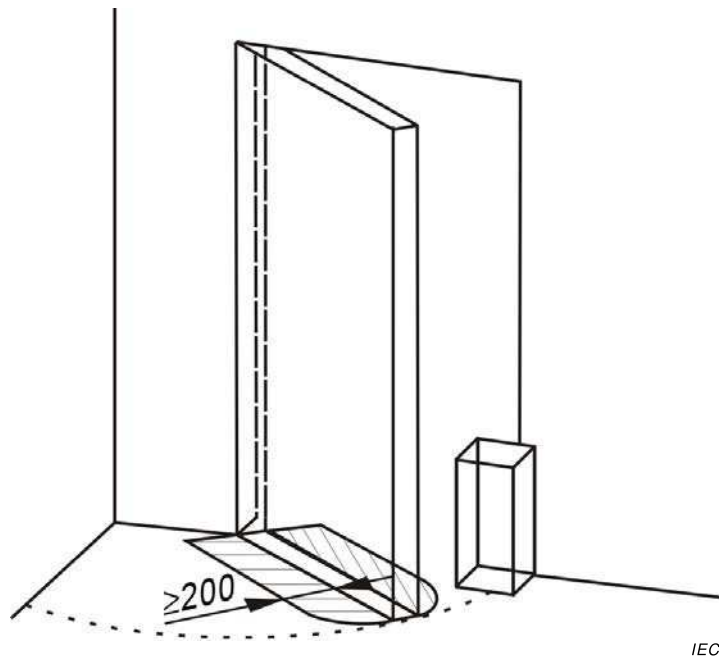

**Key**



protected area

**Figure EE.3 – Single-leaf swing doorset**

*Dimensions in millimetres*

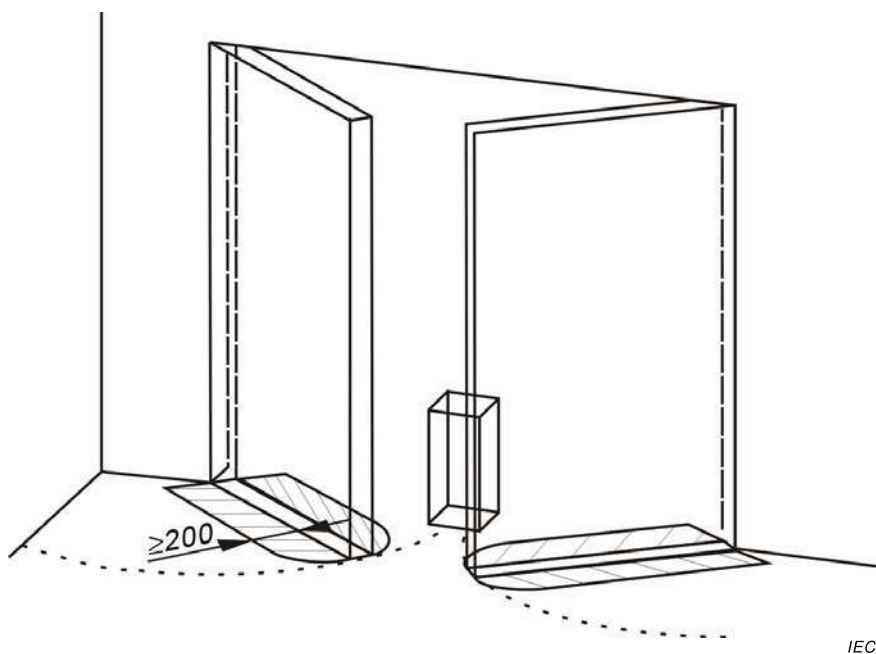

**Key**



protected area

**Figure EE.4 – Double-leaf swing doorset**

*Dimensions in millimetres*

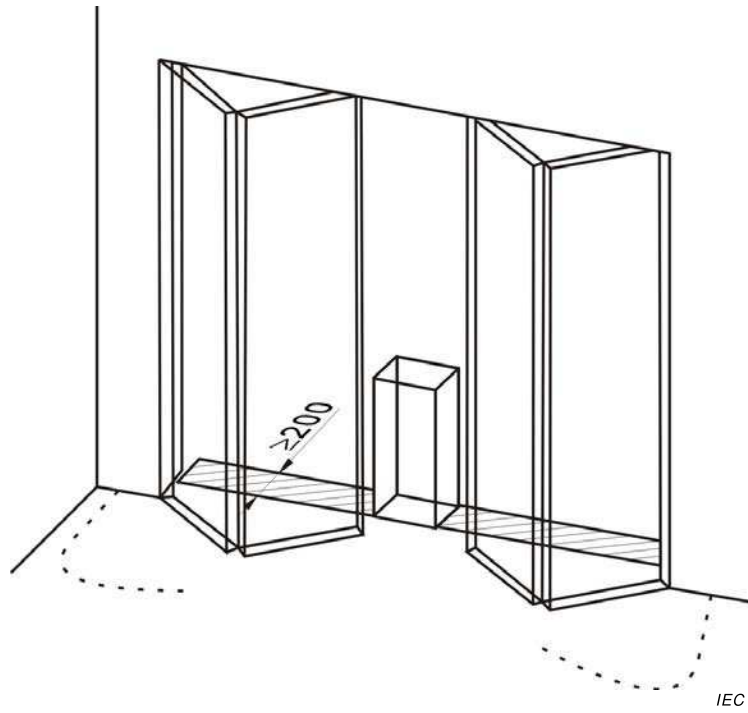

**Key**



protected area

**Figure EE.5 – Folding doorset**

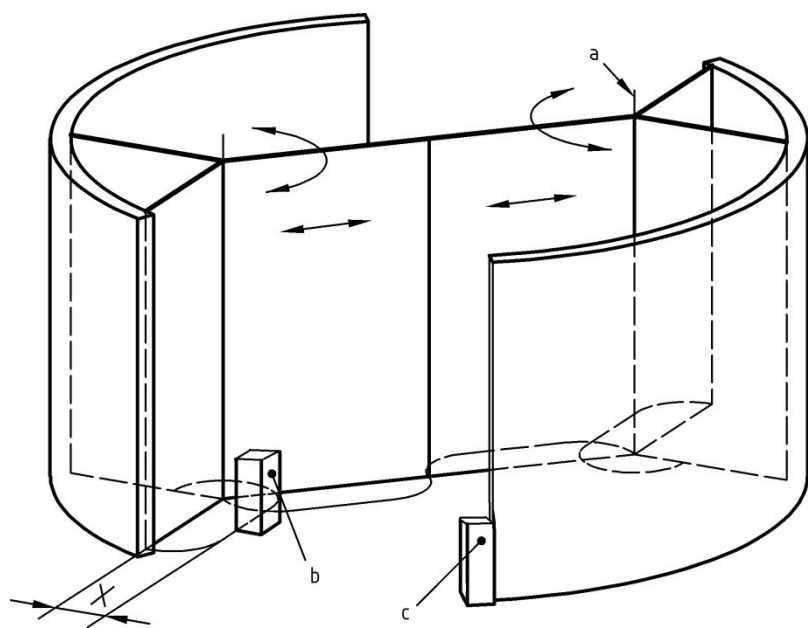

IEC

**Key**

- a pivot point for doorsets with a break-out system
- b test 1 (with CA) for doorset diameters greater than 3 000 mm
- c test 2 (with CA) for all doorset diameters, see also Clause GG.1 in Annex GG
- X protected area

**a) Reference body positions for test 1 and test 2**

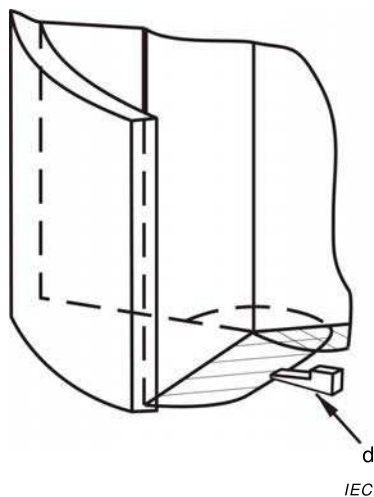

IEC

**Key**

- d test 3 (with CB) in centre of doorset leaf

**b) Reference body position for test 3**

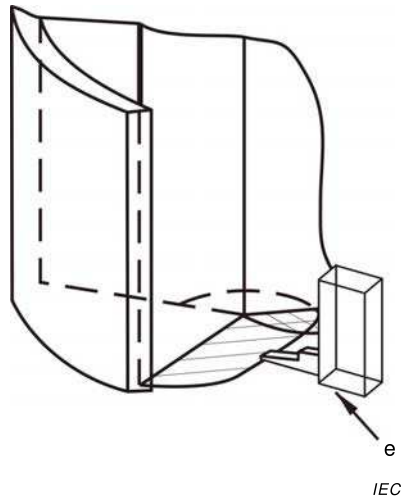

**Key**

e test 4 (with the combination of CB and CA) for all doorset diameters, in centre of doorset leaf

**c) Reference body position for test 4**

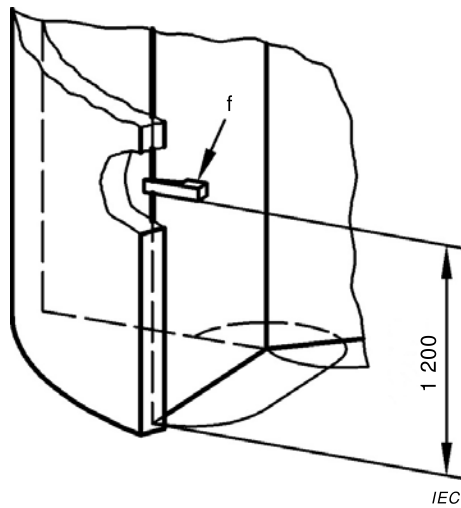

**Key**

f test 5 (with CB) for all doorset diameters

**d) Reference body position for test 5**

**Figure EE.6 – Revolving doorset, two leaves**

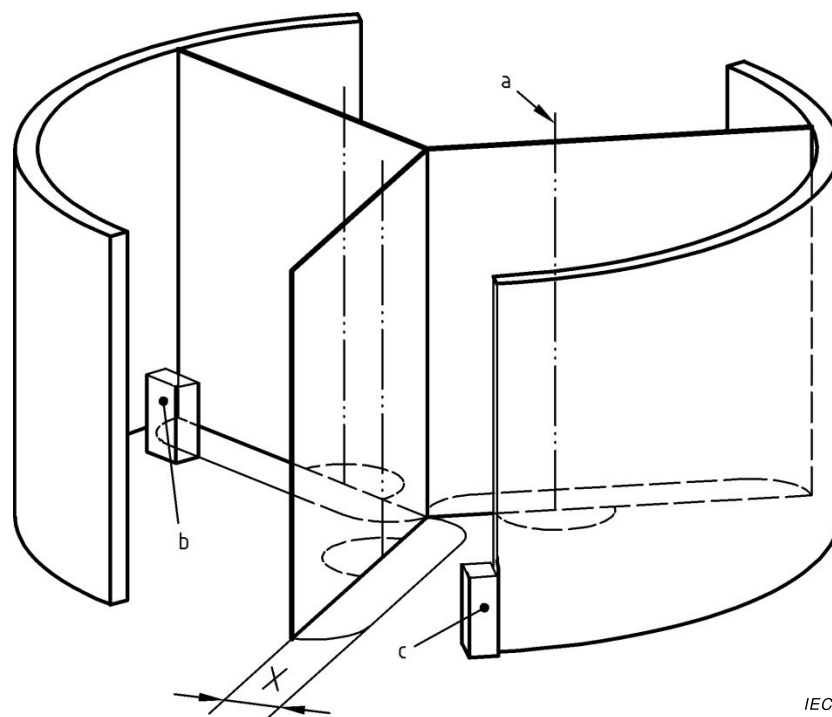

**Key**

- a pivot point for doorsets with a break-out system
- b test 1 (with CA) for doorset diameters greater than 3 000 mm, see also GG.1 in Annex GG
- c test 2 (with CA) for all doorset diameters, see also Clause GG.1 in Annex GG
- X protection area

**a) Reference body positions for test 1 and test 2**

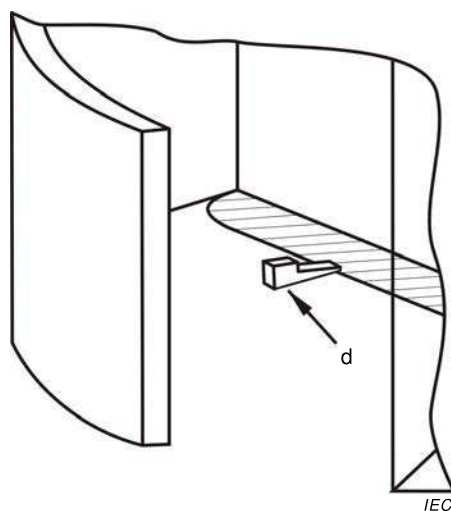

**Key**

- d test 3 (with CB) in centre of doorset leaf

**b) Reference body position for test 3**

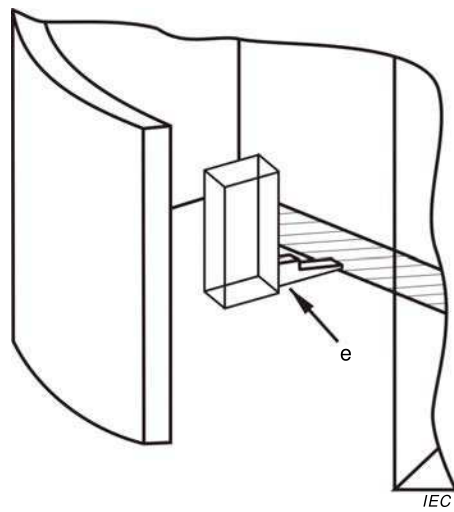

**Key**

e test 4 (with the combination of CB and CA) for all doorset diameters, in centre of doorset leaf

**c) Reference body position for test 4**

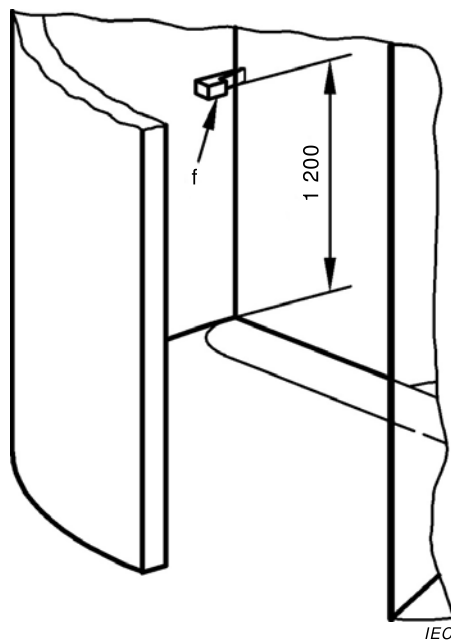

**Key**

f test 5 (with CB) for all doorset diameters

**d) Reference body position for test 5**

**Figure EE.7 – Revolving doorset, three leaves**

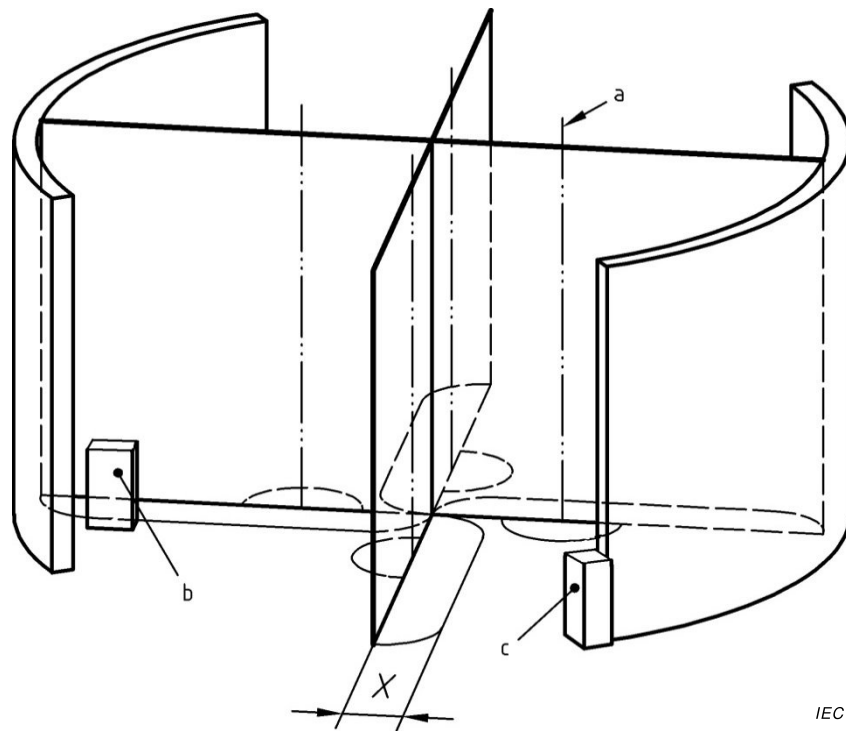

**Key**

- a pivot point for doorsets with a break-out system
- b test 1 (with CA) for doorset diameters greater than 3 000 mm
- c test 2 (with CA) for all doorset diameters, see also Clause GG.1 in Annex GG
- X protection area

**a) Reference body positions for test 1 and test 2**

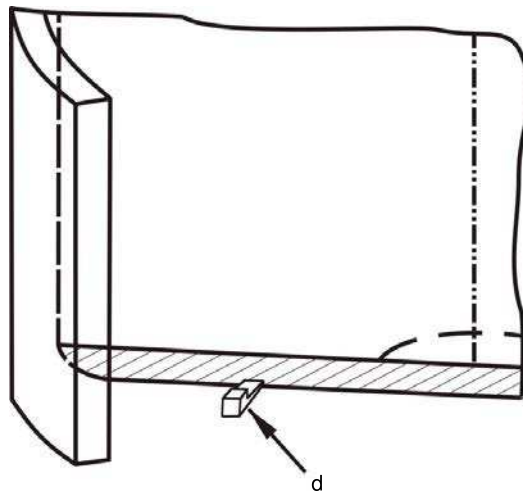

**Key**

- d test 3 (with CB) in centre of doorset leaf

**b) Reference body position for test 3**

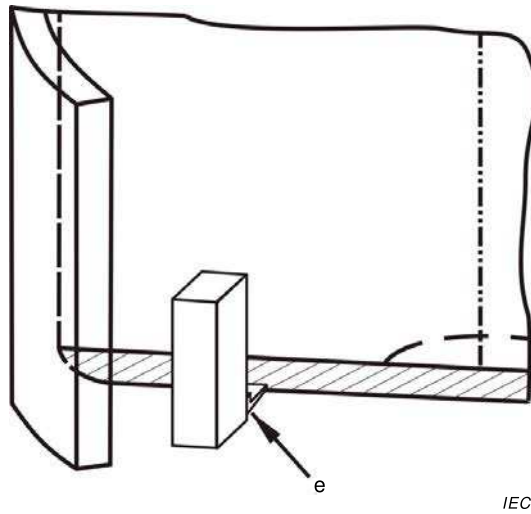

**Key**

e test 4 (with the combination of CB and CA) for all doorset diameters, in centre of doorset leaf

**c) Reference body position for test 4**

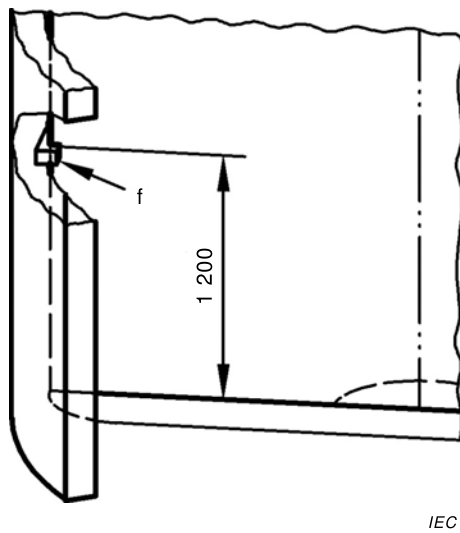

**Key**

f test 5 (with CB) for all doorset diameters

**d) Reference body position for test 5**

**Figure EE.8 – Revolving doorset, four leaves**

## Annex FF (normative)

### Reference bodies

Annex FF is applicable to **entrapment protection system** sensing devices based on active optoelectronic protective devices responsive to diffuse reflection (AOPDDRs) using a radiation wavelength in the range 820 nm to 946 nm. For sensing devices using other technologies, this annex may be used as a guide.

An **entrapment protection system** shall always be tested on a complete power operated doorset assembly.

The CA reference body (see Figure FF.1a) is a box with the dimensions 0,7 m × 0,3 m × 0,2 m. Both the top side and two sides that meet are made of a material with a diffuse reflectance value in the range of 2 % to 5 % of the wavelength of the **entrapment protection system** transmitter (e.g. IC antistatic foam; see also Figure 3 of IEC 61496-3:2008 for further materials) while the other two sides are made of a material with a diffuse reflectance value in the range of 80 % to 90 % of the wavelength of the **entrapment protection system** transmitter (e.g. white paper). The base of the reference body is not defined as it does not serve any purpose in the test.

The CB reference body (SEE Figure FF.1b) is made of a matt-black elastomer with a Shore-A hardness of  $70 \pm 5$  and a diffuse reflectance value in the range of 10 % to 90 % of the wavelength of the **entrapment protection system** transmitter.

The reference body shall be detected and the doorset shall then either stop before it touches the reference body, or reverse or switch over to low-speed motion as described in the product documentation.

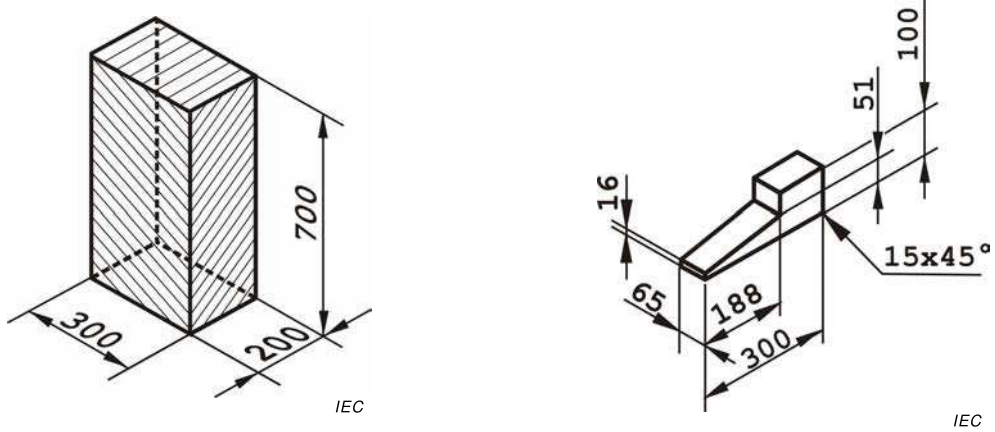

**Entrapment protection systems** which do not move with the doorset leave(s) shall be tested using all relevant sides of the CA reference body.

Dimensions in millimetres



a) CA reference body

b) CB reference body

-  Diffuse reflectance value in the range of 2 % to 5 % at the wavelength of the transmitter of the **entrapment protection system**
-  Diffuse reflectance value in the range of 80 % to 90 % at the wavelength of the transmitter of the **entrapment protection system**

-  Diffuse reflectance value in the range of 10 % to 90 % at the wavelength of the transmitter of the **entrapment protection system**

**Figure FF.1 – Reference bodies**

## **Annex GG** (normative)

### **Test method of entrapment protection system of drives for revolving doors**

#### **GG.1 Main closing edge/opposing closing edge – no contact protection**

If the hazard between the main closing edge and opposing closing edge is protected by an **entrapment protection system** not allowing contact with the doorset it shall be tested using a CA reference body (see Annex FF). The CA reference body shall be located next to the opposing closing edge and shall not be touched by the doorset leaf (see test 2 in Figures EE.6a, EE.7a and EE.8a).

For doorsets diameters greater than 3 000 mm the CA reference body shall additionally be located next to the edge of the doorset moving leaf and shall not be touched by the doorset leaf itself (see test 1 in Figures EE.6a, EE.7a and EE.8a)

#### **GG.2 Main closing edge/opposing closing edge – contact protection**

If the hazard between the main closing edge and opposing closing edge is protected by a device or combination of devices allowing contact with the doorset it shall be tested by a force measurement according to Annex HH at an opening width as specified in Figures II.4 or II.5 or II.6. If electro-sensitive protective equipment (ESPE) is used for speed reduction, the test shall be carried out at the speed after activation of the ESPE.

#### **GG.3 Secondary closing edge/floor**

The **entrapment protection system** protecting the hazard between the secondary closing edge and the floor shall be tested using the CB reference body.

The CB reference body is positioned on the floor so that it cannot be pushed away. The doorset shall come to a stop without completely passing over the reference body or the reference body being touched by the doorset leaf in the slanted areas. Contact with the flexible parts of the protective equipment is accepted (see test 3 in Figures EE.6c, EE.7c and EE.8c). If an **entrapment protection system** is used for speed reduction, the test shall be carried out with the combination of test bodies CB and CA (see test 4 in Figures EE.6d, EE.7d and EE.8d).

The test need not be performed if this hazard is safeguarded by safety distances.

#### **GG.4 Main closing edge/inside wall**

The **entrapment protection system** protecting the hazard between main closing edge and the inside wall shall be tested by means of the CB reference body.

The reference body is positioned at a height of 1 200 mm above the floor on the drum wall as shown in test 5 in Figures EE.6d, EE.7d and EE.8d. During the test, the reference body shall not come into contact with the doorset leaf. Contact with the flexible parts of the protective equipment is accepted.

## Annex HH (normative)

### Limitation of impact forces of pedestrian doors

#### HH.1 Permissible dynamic forces

The values of dynamic force generated by the doorset leaf when impacting a person or an obstacle shall be considered to be safe if the limits specified in Table HH.1 are not exceeded, when measured according to Annex II with an instrument complying with Clause HH.3 or HH.4.

**Table HH.1 – Permissible dynamic forces**

Doorset type	Permissible dynamic forces			Measuring points
	Between closing edges and opposing closing edges in gaps of <sup>a</sup>			
	< 200 mm	200 mm to 500 mm	> 500 mm	
Sliding doorset and sliding/swing (balanced) doorset	400 N	700 N	1 400 N	Figures II.1 and II.2
Folding doorset	400 N	700 N	1 400 N	Figures II.3
Revolving doorset	400 N	700 N	1 400 N	Figures II.4 to II.6
Flat areas are areas other than closing edges > 0,1 m <sup>2</sup> and with no side < 100 mm.				
The above values shall be the maximum allowed within a maximum period of time of 0,75 s ( $T_d < 0,75$ s).				
<sup>a</sup> The opposing closing edge may also be a second main closing edge or flat areas around the opening doorset.				

The leaf force measurements shall not exceed the profile shown in Figure HH.1.

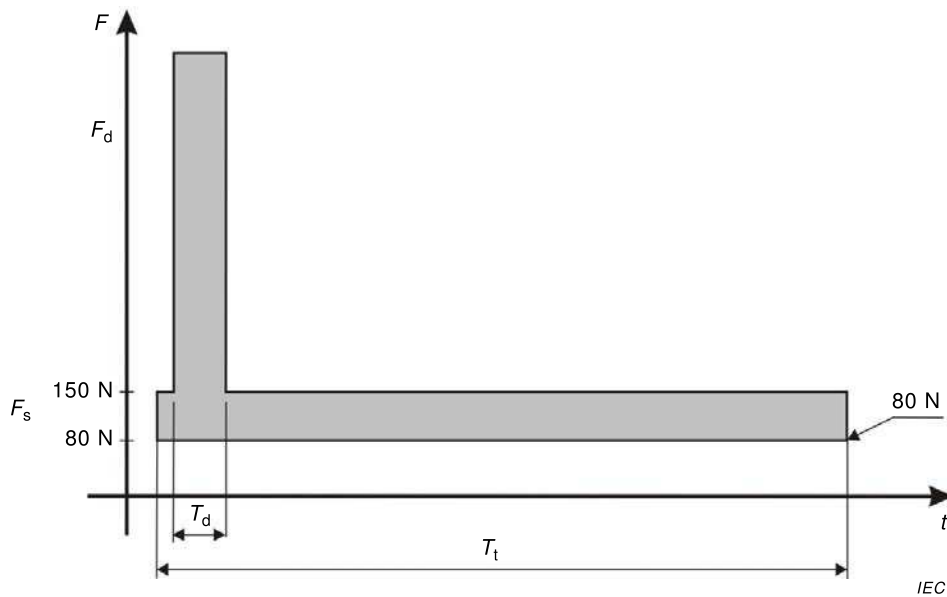

#### Key

- $F_d$  maximum force measured during the dynamic period  $T_d$  (dynamic force) – see Table 1 for permitted values
- $T_d$  period of time of max. 0,75 s starting from the first measured force exceeding 150 N
- $F_s$  maximum force measured outside the dynamic period  $T_d$  (static force)
- $T_t$  period of 5 s starting from the first measured force exceeding 80 N and including  $T_d$

**Figure HH.1 – Force versus time**

### HH.2 Permissible static forces

After  $T_d$  has elapsed, no static force  $>150$  N is allowed. This static force shall come down to  $< 80$  N after a total time  $T_t$  of maximum 5 s.

However, after  $T_d$ , peaks exceeding 150 N but lower than the admissible dynamic forces shown in Table 1 are accepted if:

- they are decreasing from one to the other; and
- the period of oscillation is  $\leq 1$  s; and
- the average force calculated over the period of  $T_t - T_d$  is  $\leq 150$  N.

### HH.3 Impact force measuring equipment

The test equipment for measuring forces shall consist of the following parts:

- a) two contact areas with a diameter of 80 mm. The contact areas shall be made of a hard material with sufficient strength, e.g. steel;
- b) spring that gives the contact area a spring ratio of  $500 \text{ N/mm} \pm 50 \text{ N/mm}$ ;
- c) load cell;
- d) time measuring device;
- e) measuring value display/measuring value output device.

The measuring equipment shall comply with the following specification:

- rising/falling time of the load cell amplifier  $< 5$  ms;

- the equipment shall be able to give measured values with an accuracy of at least  $\pm 5\%$  or  $\pm 10\text{ N}$ , whichever is the maximum deviation;
- measurements to be given in graphical form or by displaying the values.

#### **HH.4 Field impact force measuring equipment**

Field measuring equipment need not display the values and accuracy shall at least be  $\pm 10\%$  or  $\pm 20\text{ N}$  of measured values, whichever is the maximum deviation. Calibration shall be performed at least once per year.

## Annex II (normative)

### Measuring points for limitation of impact forces of pedestrian doors

Forces (see Table HH.1) shall be measured at the measuring points ( $F$ ) shown in Figures II.1 to II.6 with the instrument of Clause HH.3 or HH.4.

*Dimensions in millimetres*

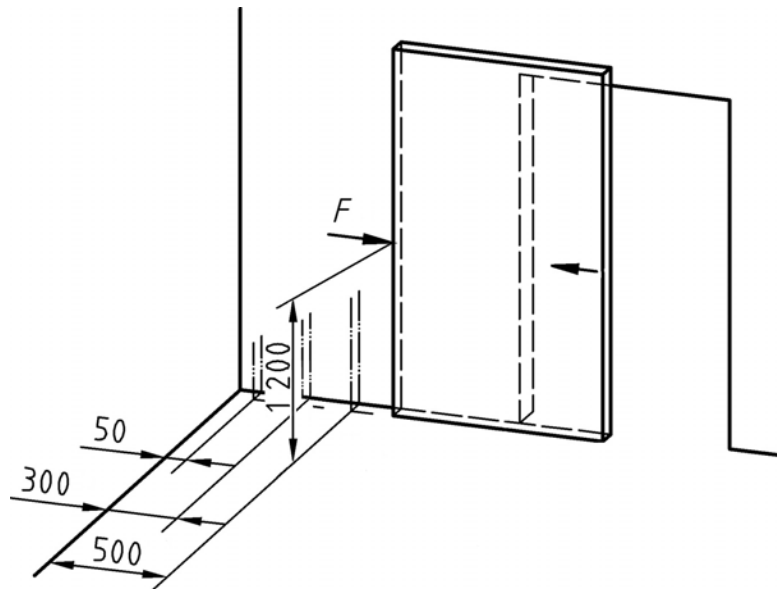

IEC

**Figure II.1 – Single-leaf sliding doorset**

*Dimensions in millimetres*

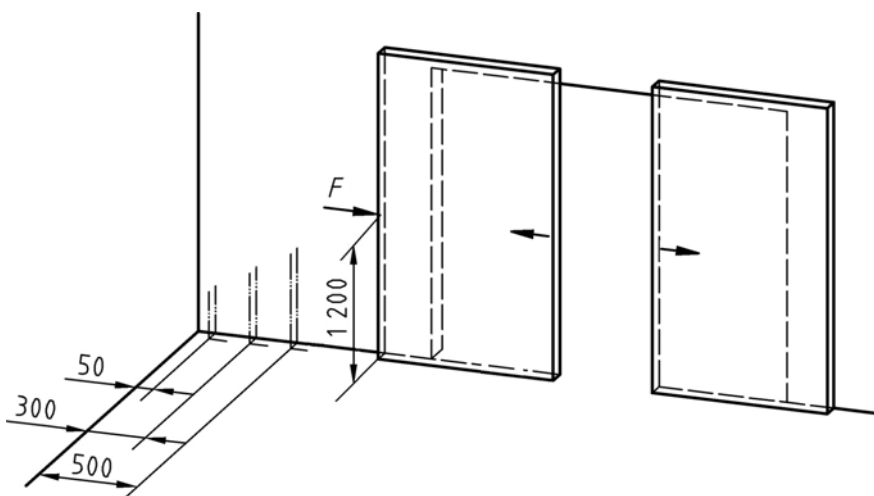

IEC

**Figure II.2 – Double-leaf sliding doorset**

*Dimensions in millimetres*

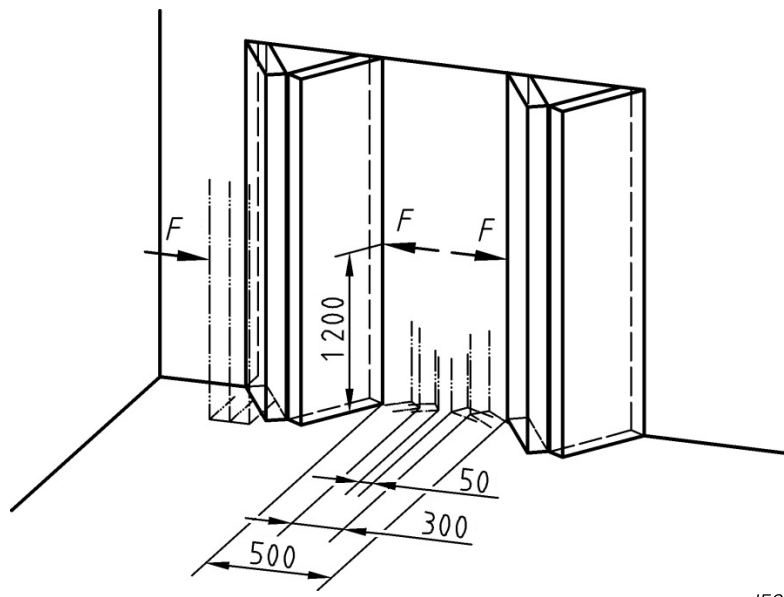

IEC

**Figure II.3 – Folding doorset**

*Dimensions in millimetres*

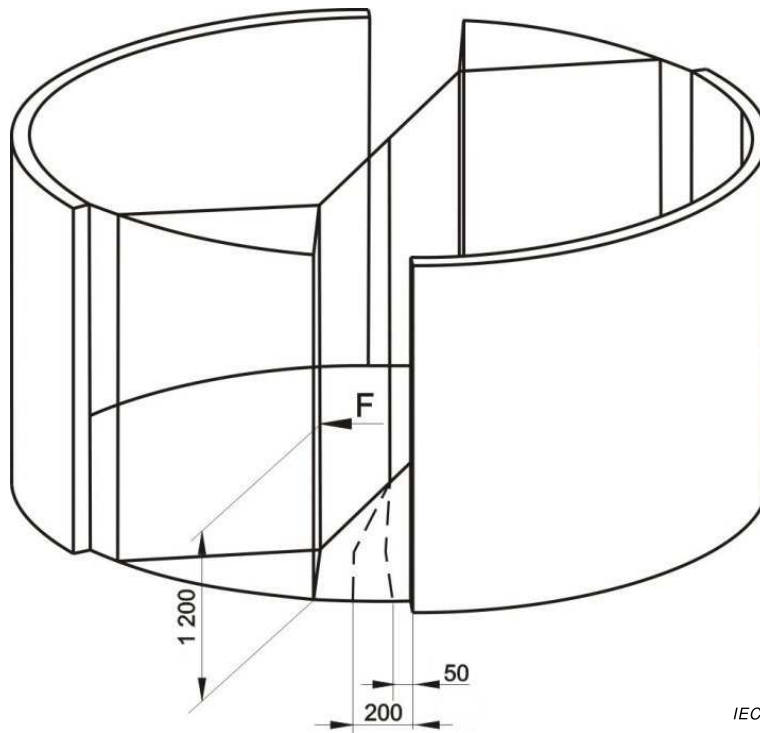

IEC

**Figure II.4 – Revolving doorset, 2-leaf**

*Dimensions in millimetres*

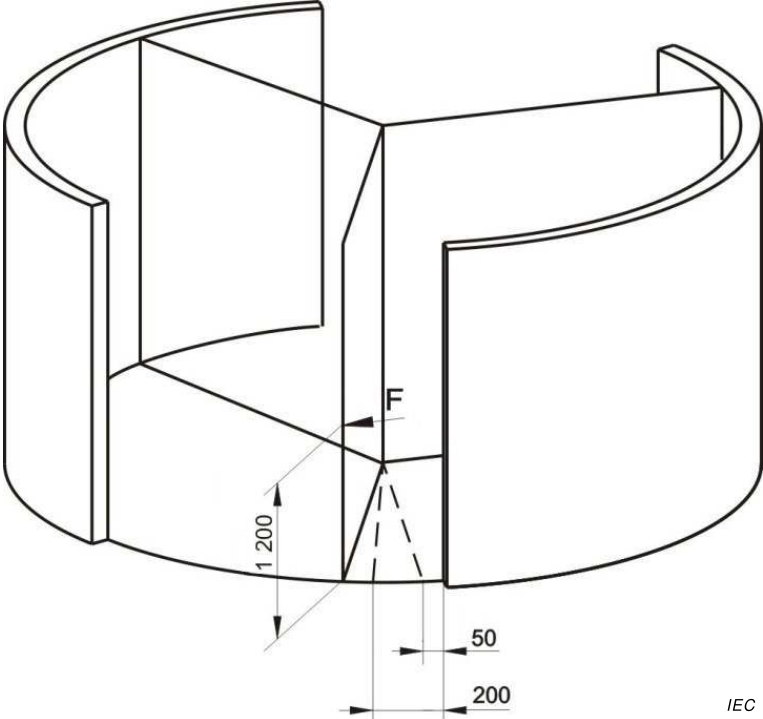

IEC

**Figure II.5 – Revolving doorset, 3-leaf**

*Dimensions in millimetres*

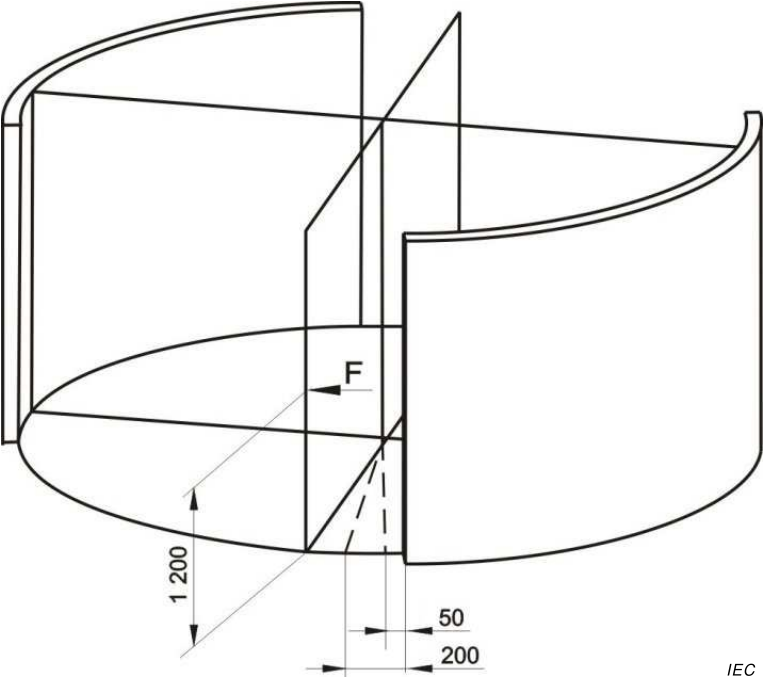

IEC

**Figure II.6 – Revolving doorset, 4-leaf**

## **Annex JJ** (normative)

### **Low energy movement of pedestrian doors**

#### **JJ.1 Low energy movement**

##### **JJ.1.1 General**

The force required to prevent a stopped doorset from opening or closing any further – measured at the main closing edge in the direction of travel – shall not exceed 67 N at any point in the opening or closing **cycle**.

The kinetic energy of a doorset in motion shall not exceed 1,69 J. Annex KK states the speed settings for various widths and masses of doorsets required to obtain results conforming to this requirement.

In the event of any interruption of mains power or failure of the **drive**, it shall be possible to open the doorset with a manual force not exceeding 67 N to release a latch and 90 N to open the doorset, when the force is applied to the main closing edge in the direction of travel.

Low energy movement of the doorset is generally not protected with additional protective devices because the kinetic energy levels are not considered to be hazardous. However, use of low energy doorset movement should only be considered when the risk assessment has taken account of elderly, frail and disabled users and indicates that the risk to these users is low.

A static closing force up to 150 N is allowed:

- when the gap between the main closing edge and the counter-closing edge is  $\leq 8$  mm for swing doorsets; or
- during the last 50 mm for any type of sliding and folding doorsets.

##### **JJ.1.2 Additional requirements for low-energy movement of hinged and swing doorsets**

###### **JJ.1.2.1 Opening time**

Doorsets shall open from closed to back check, or 80° whichever occurs first, in 3 s or longer as required in Table KK1. Back check shall not occur before 60° opening. If the doorset opens more than 90°, it shall continue at the same rate as back check speed.

NOTE Back check – Back check is the checking or slowing down of the speed of doorset opening before being fully opened (also called open check).

###### **JJ.1.2.2 Closing time**

It shall be possible to adjust the doorset on site to close from 90° to 10° in not less than 3 s and from 10° to fully closed in not less than 1,5 s as required in Table KK.1.

## Annex KK (normative)

### Speed setting for low energy movement of pedestrian doors

#### KK.1 Speed settings for low energy power operated swing doorsets

Table KK.1 shows the minimum opening time (in seconds) to back-check or to 80° open or minimum closing time (in seconds) from 90° to 10° open for most common doorset widths and masses.

**Table KK.1 – Speed settings**

Width of doorset leaf m	Mass of doorset leaf kg				
	50	60	70	80	90
	Time s				
0,75	3,0	3,0	3,0	3,0	3,2
0,85	3,0	3,0	3,2	3,4	3,6
1,00	3,2	3,4	3,7	4,0	4,2
1,20	3,8	4,1	4,5	4,8	5,0

NOTE Calculated with an energy 1,69 J and values for time rounded up to nearest one decimal place.

The minimum opening time for doorsets of other widths and/or masses shall be calculated using the following formula:

$$t = \frac{D\sqrt{m}}{2,26}$$

where

$t$  is the time, in s;

$D$  is the doorset width, in m;

$m$  is the mass of the doorset leaf, in kg;

2,26 is the conversion factor (units  $\text{mKg}^{1/2} \text{s}^{-1}$ ).

#### KK.2 Speed settings for low energy sliding doorsets

Table KK.2 shows the minimum travelling time per doorset leaf referred to the doorset mass and the travelling distance per doorset leaf.

**Table KK.2 – Minimum travelling time per doorset leaf vs. mass of door leaf**

90 % travelling distance per leaf <i>D</i>  m	Mass of doorset leaf <i>m</i> kg														
	150	140	130	120	110	100	90	80	70	60	50	40	30	20	10
	Maximum travelling speed <i>v</i> m/s														
	0,15	0,16	0,16	0,17	0,18	0,18	0,19	0,21	0,22	0,24	0,26	0,29	0,34	0,41	0,58
Minimum travelling time <i>t</i> s															
0,7	4,7	4,6	4,4	4,2	4,0	3,9	3,7	3,5	3,2	3,0	2,7	2,5	2,1	1,8	1,3
0,8	5,4	5,2	5,0	4,8	4,6	4,4	4,2	3,9	3,7	3,4	3,1	2,8	2,4	2,0	1,4
0,9	6,0	5,8	5,6	5,4	5,2	4,9	4,7	4,4	4,1	3,8	3,5	3,1	2,7	2,2	1,6
1,0	6,7	6,5	6,3	6,0	5,8	5,5	5,2	4,9	4,6	4,3	3,9	3,5	3,0	2,5	1,8
1,1	7,4	7,1	6,9	6,6	6,3	6,0	5,7	5,4	5,1	4,7	4,3	3,8	3,3	2,7	1,9
1,2	8,0	7,8	7,5	7,2	6,9	6,6	6,2	5,9	5,5	5,1	4,7	4,2	3,6	3,0	2,1
1,3	8,7	8,4	8,1	7,8	7,5	7,1	6,8	6,4	6,0	5,5	5,0	4,5	3,9	3,2	2,3
1,4	9,4	9,1	8,7	8,4	8,0	7,7	7,3	6,9	6,4	5,9	5,4	4,9	4,2	3,5	2,5
1,5	10,0	9,7	9,4	9,0	8,6	8,2	7,8	7,3	6,9	6,4	5,8	5,2	4,5	3,7	2,6

NOTE For telescopic sliding doorsets, the travelling distance applies to the fast moving leaf.

The maximum speed for doorsets of other masses shall be calculated using the kinetic energy formula, considering that the maximum admitted energy is 1,69 J:

$$E_c = \frac{1}{2} m v^2 = 1,69 \text{ (J)}$$

By knowing the leaf weight it is possible to calculate the maximum allowed speed as follows:

$$v = \sqrt{\frac{2E_c}{m}} \text{ (m/s)}$$

where

*v* is the speed, in m/s;

*E<sub>c</sub>* is the kinetic energy, in J (always 1,69 J);

*m* is the mass of the doorset leaf, in kg.

Time settings for other travelling distances per leaf and masses shall be calculated using the following formula:

$$t = \frac{D}{v}$$

where

*t* is the travelling time for opening or closing, in (s);

*D* is 90 % of the travelling distance of the leaf, in (m);

*v* is the doorset speed, in (m/s).

## Annex LL (normative)

### Safeguarding of swing pedestrian doors

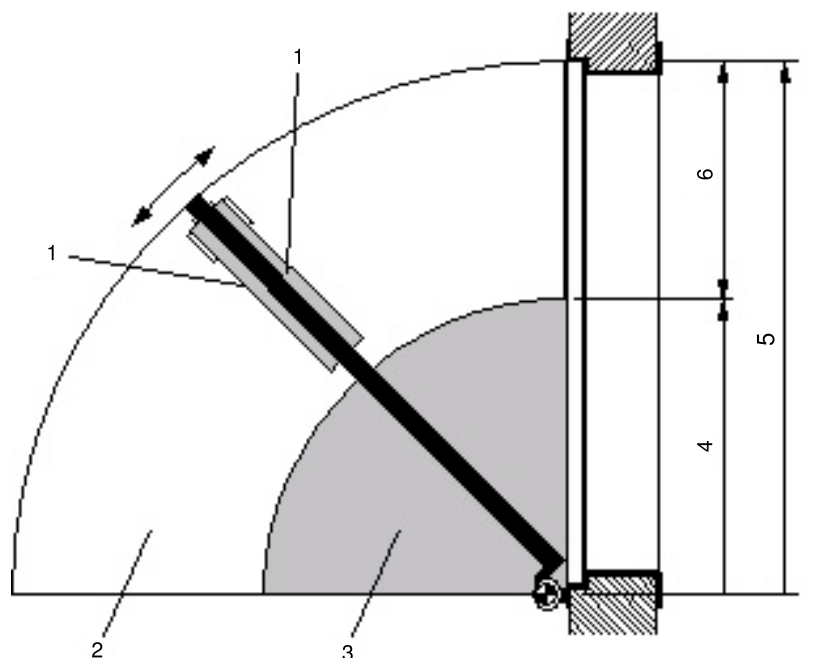

IEC

#### Key

- 1 protective device
- 2 fast area requiring protection
- 3 slow area
- 4 radius of slow area ( $r_{\text{slow area}}$ )
- 5 radius of the door ( $r_{\text{doorset}}$ )
- 6 radius of the protected area ( $d_{\text{protected}}$ )

**Figure LL.1 – Areas of the door sweep**

Figure LL.1 shows the areas of the door sweep.

Table LL.1 shows the minimum distance from the leading edge to be protected.

**Table LL.1 – Minimum width of door leaf to be protected vs. radius of doorset and doorset travelling time**

$r_{\text{doorset}}$ m	Time s										
	1	1,5	2	2,5	3	3,5	4	4,5	5	5,5	6
	$r_{\text{slow area}}$ m										
	0,16	0,24	0,32	0,4	0,48	0,56	0,64	0,72	0,8	0,88	0,95
$d_{\text{protected}}$ m											
0,7	0,54	0,46	0,38	0,30	0,22	0,14	0,06	–	–	–	–
0,8	0,64	0,56	0,48	0,40	0,32	0,24	0,16	0,08	–	–	–
0,9	0,74	0,66	0,58	0,50	0,42	0,34	0,26	0,18	0,10	0,02	–
1,0	0,84	0,76	0,68	0,60	0,52	0,44	0,36	0,28	0,20	0,12	0,05
1,1	0,94	0,86	0,78	0,70	0,62	0,54	0,46	0,38	0,30	0,22	0,15
1,2	1,04	0,96	0,88	0,80	0,72	0,64	0,56	0,48	0,40	0,32	0,25
1,3	1,14	1,06	0,98	0,90	0,82	0,74	0,66	0,58	0,50	0,42	0,35
1,4	1,24	1,16	1,08	1,00	0,92	0,84	0,76	0,68	0,60	0,52	0,45
1,5	1,34	1,26	1,18	1,10	1,02	0,94	0,86	0,78	0,70	0,62	0,55
1,6	1,44	1,36	1,28	1,20	1,12	1,04	0,96	0,88	0,80	0,72	0,65
1,7	1,54	1,46	1,38	1,30	1,22	1,14	1,06	0,98	0,90	0,82	0,75
1,8	1,64	1,56	1,48	1,40	1,32	1,24	1,16	1,08	1,00	0,92	0,85

The opening time is measured from 0° to 80° and the closing time from 90° to 10°

$r_{\text{slow area}}$  and the width of the doorset which needs to be protected ( $d_{\text{protected}}$ ) by protective devices for doorsets with other opening and closing times shall be calculated using the following formulas:

$$r_{\text{slow area}} = \frac{2}{\pi} \cdot v \cdot t = 0,16 \cdot t$$

$$d_{\text{protected}} = r_{\text{doorset}} - r_{\text{slow area}}$$

where

$t$  is the time, in s;

$r_{\text{slow area}}$  is the radius of the slow area, in m;

$v$  is the max. allowed collision speed of 0,25 m/s;

0,16 is the conversion factor, in m/s;

$d_{\text{protected}}$  is the width of the doorset which needs to be protected.

## Bibliography

The bibliography of Part 1 is applicable except as follows.

*Addition:*

IEC 60335-2-95, *Household and similar electrical appliances – Safety – Part 2-95: Particular requirements for drives for vertically moving garage doors for residential use*

IEC 60335-2-97, *Household and similar electrical appliances – Safety – Part 2-97: Particular requirements for drives for rolling shutters, awnings, blinds and similar equipment*

ISO 21927-2, *Smoke and heat control systems – Part 2: Specification for natural smoke and heat exhaust ventilators*

---





INTERNATIONAL  
ELECTROTECHNICAL  
COMMISSION

3, rue de Varembé  
PO Box 131  
CH-1211 Geneva 20  
Switzerland

Tel: + 41 22 919 02 11  
Fax: + 41 22 919 03 00  
[info@iec.ch](mailto:info@iec.ch)  
[www.iec.ch](http://www.iec.ch)